

# FR3535RGB4C-F2T

3.5x3.5mm, Intelligent control LED  
PLCC-4 Package integrated light source



## Technical Data Sheet

---

### Features:

- PLCC-4 package.
- Intelligent reverse connect protection, the power supply reverse connection does not damage the IC.
- The control circuit and the LED share the only power source.
- Control circuit and RGB chip are integrated in a package of 3535 components, form a complete control of pixel point.
- Built-in signal reshaping circuit, after wave reshaping to the next driver, ensure wave-form distortion not accumulate.
- Built-in electric reset circuit and power lost reset circuit.
- Each pixel of the three primary color can achieve 256 brightness display, completed 16777216 color full color display, and scan frequency not less than 400Hz/s.
- Cascading port transmission signal by single line.
- Any two point the distance more than 5m transmission signal without any increase circuit.
- When the refresh rate is 30fps, cascade number are not less than 1024 points.
- Send data at speeds of 800Kbps.

### Applications:

- Full-color module, Full color soft lights a lamp strip.
- LED decorative lighting, Indoor/outdoor LED video irregular screen.

Part No.	Emitting Color		Lens Color
FR3535RGB4C-F2T	R	Red	Water Clear
	G	Pure Green	
	B	Blue	

# FR3535RGB4C-F2T

3.5x3.5mm, Intelligent control LED  
PLCC-4 Package integrated light source



## Technical Data Sheet

### Package Dimension:

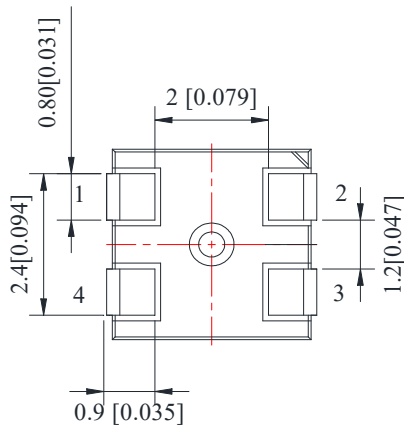
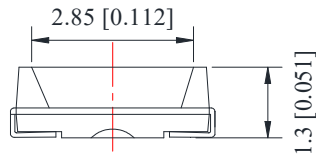
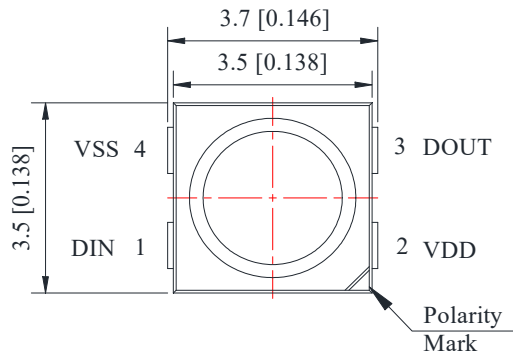

### Pin Function

- 1 DIN: Control Data Signal Input
- 2 VDD: Power Supply LED
- 3 DOUT: Control Data Signal Output
- 4 VSS: Ground

### Recommended Soldering Pad dimensions

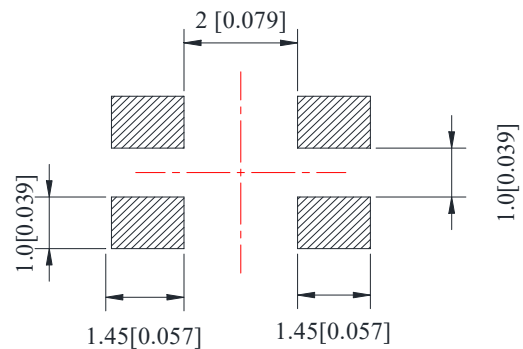

### Notes:

- 1. All dimensions are in millimeters (inches).
- 2. Tolerance is  $\pm 0.25$  mm (.010") unless otherwise noted.
- 3. Protruded resin under flange is 1.00mm (.039") max.

# FR3535RGB4C-F2T

3.5x3.5mm, Intelligent control LED  
PLCC-4 Package integrated light source



## Technical Data Sheet

### Absolute Maximum Ratings at Ta=25°C

Parameter	Symbol	Ratings	Unit
Power supply voltage	VDD	+3.5~+5.5	V
Input voltage	VI	-0.5~VDD+5.5	V
Operation junction temperature	Topt	-40~+80	°C
Storage temperature range	Tstg	-40~+105	°C

### Electrical Characteristics: (TA=-20~+70°C, VDD=4.5~5.5V, VSS=0V, unless otherwise specified)

Parameter	Symbol	conditions	Min	Tpy	Max	Unit
Input current	II	VI=VDD/VSS	—	—	±1	μA
Input voltage level	VIH	DIN, SET	0.7*VDD	—	—	V
	VIL	DIN, SET	—	—	0.3* VDD	V
Output port withstand voltage	Vds	—	8.5	9.0	9.5	V
PWM	FPWM	—	3	4	5	KHZ
Static power consumption	IDD	—	—	1	—	mA
Voltage of power supply in chip	VDD	—	—	5.0	—	V
LoI1	RGB Output current	—	—	12	—	mA

### Switching characteristics:

Parameter	Symbol	Condition	Min	Tpy	Max	Unit
Transmission delay time	tPLZ	DIN-DOUT	—	—	500	ns
Fall time	tTHZ	—	—	—	500	μs
Data transmission speed	fDIN	—	—	800	1100	KHZ
Iout	Tf/tf	VDS=1.5V T IOU=12mA	—	100	—	ns

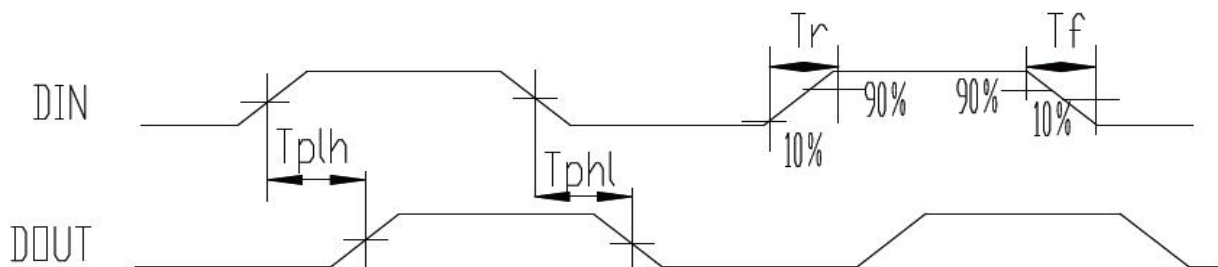

# FR3535RGB4C-F2T

3.5x3.5mm, Intelligent control LED  
PLCC-4 Package integrated light source



## Technical Data Sheet

### RGB IC characteristic parameter:( 12mA )

Emitting color	Model	Wavelength(nm)	Luminous intensity (mcd) Typ
Red	—	620-625	200-400
Green	—	520-525	800-1200
Blue	—	465-470	150-300

### Data transfer time:

Timetable name	Min.	Tpy	Max	Unit
T	0.89	--	--	us
T0H	0.2	0.295	0.35	us
T0L	0.55	0.595	1.20	us
T1H	0.55	0.595	1.20	us
T1L	0.2	0.295	0.35	us
RES	>80	--	--	us

### Notes:

- 1.The protocol uses unipolar zero-return codes. Each symbol must have a low level. Each symbol in this protocol starts at a high level. The width of high level time decides "0" code or "1" code.
- 2.When writing a program, the minimum requirement for symbol period is 1.2 us.
- 3.The high-level time of "0" code and "1" code should be in accordance with the range specified in the table above, and the low-level time of "0" code and "1" code should be less than 20 us.

### Sequence chart:

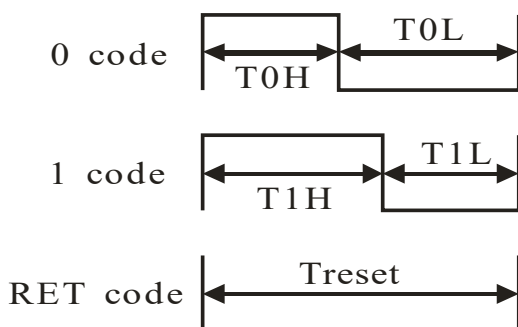

### Cascade method:

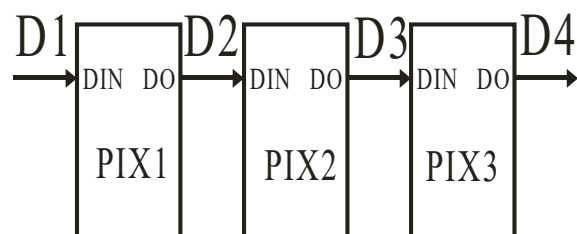

# FR3535RGB4C-F2T

3.5x3.5mm, Intelligent control LED  
PLCC-4 Package integrated light source



## Technical Data Sheet

### Data transmission method:

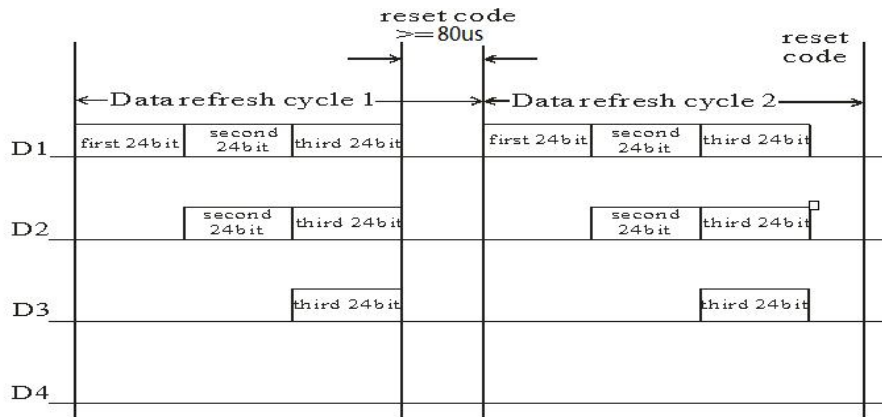

Note: The data of D1 is send by MCU, and D2, D3, D4 through pixel internal reshaping amplification to transmit.

### Composition of 24bit data:

G7	G6	G5	G4	G3	G2	G1	G0	R7	R6	R5	R4	R3	R2	R1	R0	B7	B6	B5	B4	B3	B2	B1	B0
----	----	----	----	----	----	----	----	----	----	----	----	----	----	----	----	----	----	----	----	----	----	----	----

Note: Follow the order of GRB to sent data and the high bit sent at first.

### Typical application circuit:

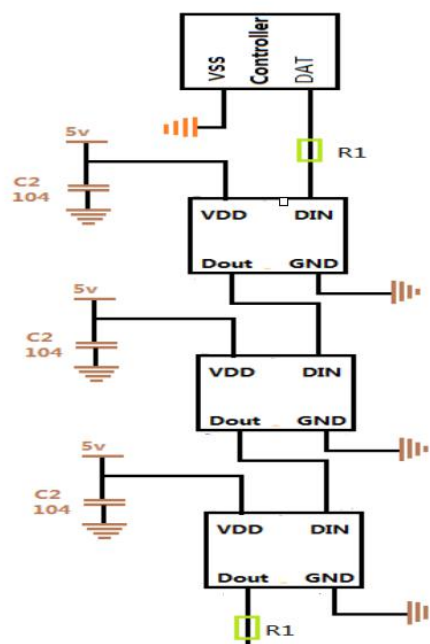

# FR3535RGB4C-F2T

3.5x3.5mm, Intelligent control LED  
PLCC-4 Package integrated light source



## Technical Data Sheet

### Reel Dimensions:

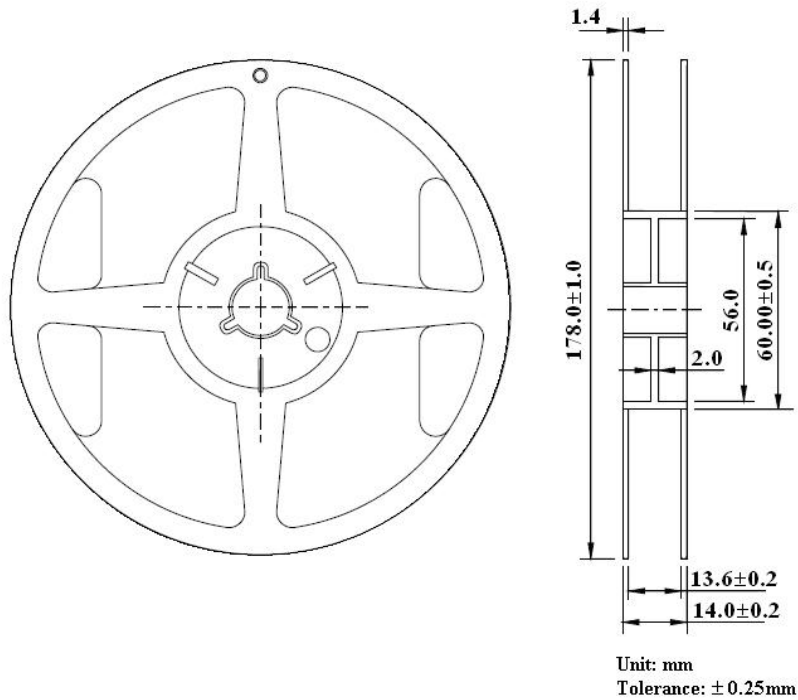

### Carrier Tape Dimensions:

Loaded quantity Max 5000 pcs per reel.

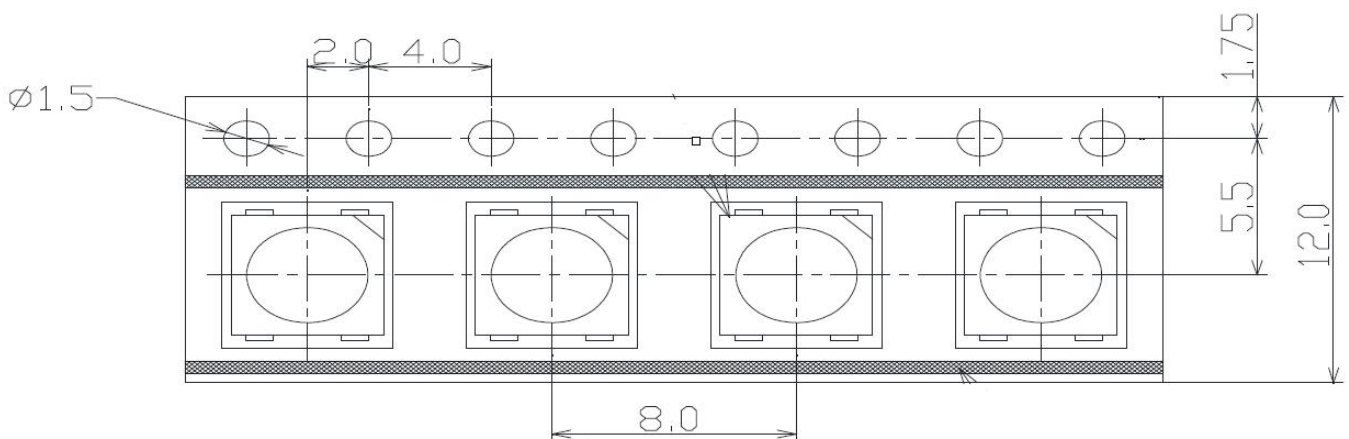

# FR3535RGB4C-F2T

3.5x3.5mm, Intelligent control LED

PLCC-4 Package integrated light source

LuckyLight

## Technical Data Sheet

### CAUTIONS

#### 1. Handling Precautions:

- 1.1. Handle the component along the side surfaces by using forceps or appropriate tools.
- 1.2. Do not directly touch or handle the silicone lens surface. It may damage the internal circuitry.
- 1.3. Do not stack together assembled PCBs containing exposed LEDs. Impact may scratch the silicone lens or damage the internal circuitry.

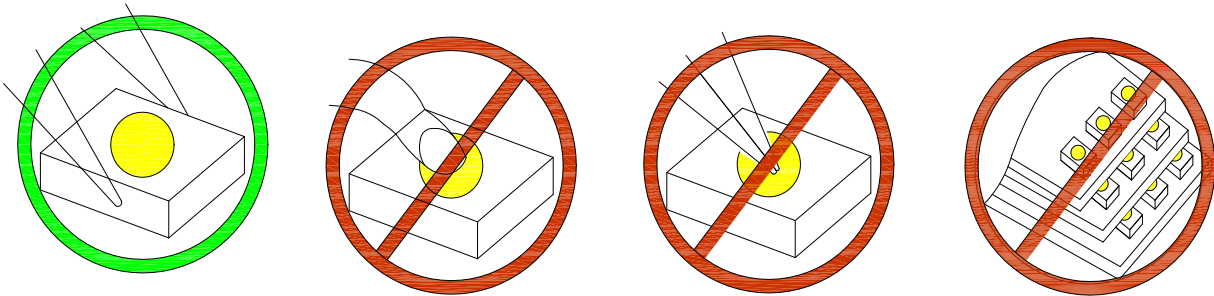

Compare to epoxy encapsulant that is hard and brittle, silicone is softer and flexible. Although its characteristic significantly reduces thermal stress, it is more susceptible to damage by external mechanical force. As a result, special handling precautions need to be observed during assembly using silicone encapsulated LED products. Failure to comply might lead to damage and premature failure of the LED.

#### 2. Storage

- 2.1. Do not open moisture proof bag before the products are ready to use.
- 2.2. Before opening the package, the LEDs should be kept at 30°C or less and 60%RH or less.
- 2.3. The LEDs should be used within a year.
- 2.4. After opening the package, the LEDs should be kept at 30°C or less and 60%RH or less.
- 2.5. The LEDs should be used within 24 hours after opening the package.
- 2.6. If the moisture adsorbent material has fabled away or the LEDs have exceeded the storage time, baking treatment should be performed using the following conditions. Baking treatment: 65±5°C for 24 hours.

#### 3. Soldering Condition

Spec No.: FR3535

Issue No.: G-Rev-4

LuckyLight Electronics Co., Ltd

Copyright © 2017 LuckyLight All Rights Reserved

Date: 28-Mar-2017

E-mail: sales@luckyLight.cn

http:// www.luckyLight.cn

Page: 7 / 10

# FR3535RGB4C-F2T

3.5x3.5mm, Intelligent control LED

PLCC-4 Package integrated light source



## Technical Data Sheet

### 3.1. Pb-free solder temperature profile

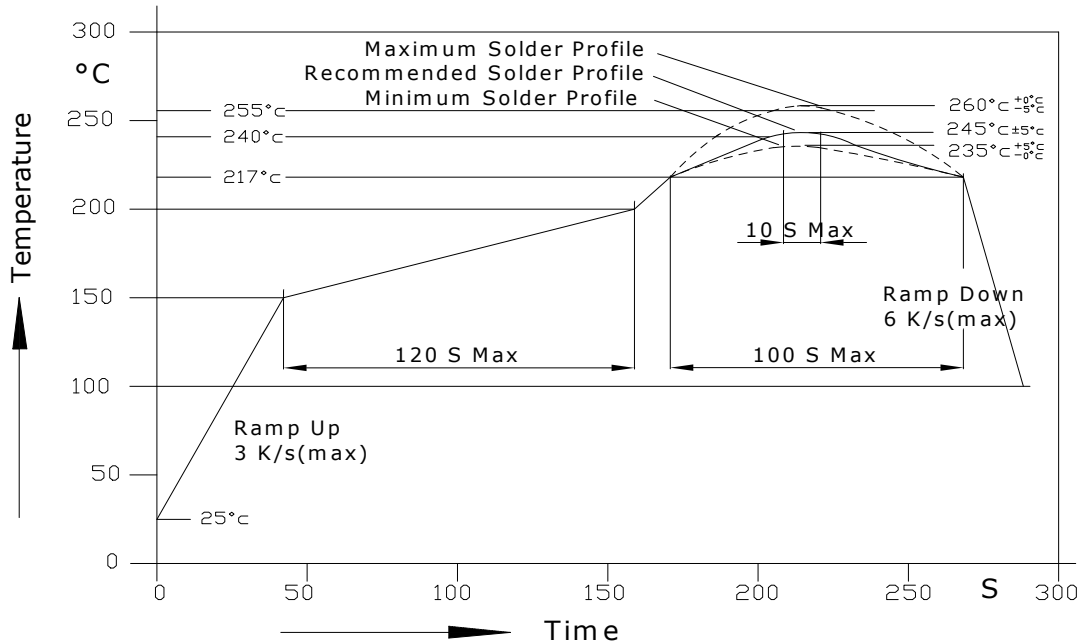

3.2. Reflow soldering should not be done more than two times.

3.3. When soldering, do not put stress on the LEDs during heating.

3.4. After soldering, do not warp the circuit board.

3.5. Recommended soldering conditions:

Reflow soldering		Soldering iron	
Pre-heat	150~200°C	Temperature	300°C Max.
Pre-heat time	120 sec. Max.	Soldering time	3 sec. Max.
Peak temperature	250°C Max.		(one time only)
Soldering time	10 sec. Max.(Max. two times)		

3.6. Because different board designs use different number and types of devices, solder pastes, reflow ovens, and circuit boards, no single temperature profile works for all possible combinations.

However, you can successfully mount your packages to the PCB by following the proper guidelines and PCB-specific

## FR3535RGB4C-F2T

3.5x3.5mm, Intelligent control LED

PLCC-4 Package integrated light source

LuckyLight

## Technical Data Sheet

---

characterization.

### 4. Drive Method

4.1. An LED is a current-operated device. In order to ensure intensity uniformity on multiple LEDs connected in parallel in an application, it is recommended that a current limiting resistor be incorporated in the drive circuit, in series with each LED as shown in Circuit A below.

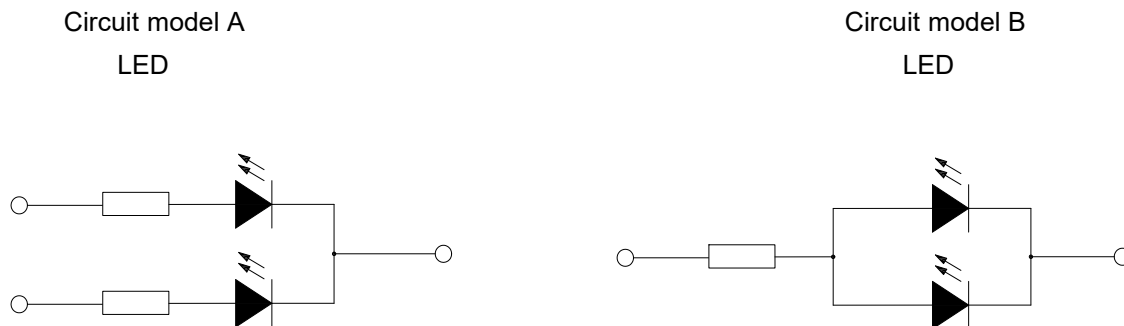

a. Recommended circuit.

b. The brightness of each LED might appear different due to the differences in the I-V characteristics of those LEDs.

### 5. ESD (Electrostatic Discharge):

Static Electricity or power surge will damage the LED. Suggestions to prevent ESD damage:

- Use of a conductive wrist band or anti-electrostatic glove when handling these LEDs.
- All devices, equipment, and machinery must be properly grounded.
- Work tables, storage racks, etc. should be properly grounded.
- Use ion blower to neutralize the static charge which might have built up on surface of the LED's plastic lens as a result of friction between LEDs during storage and handling.

ESD-damaged LEDs will exhibit abnormal characteristics such as high reverse leakage current, low forward voltage, or “no lightup” at low currents. To verify for ESD damage, check for “lightup” and  $V_f$  of the suspect LEDs at low currents. The  $V_f$  of “good” LEDs should be  $>2.0V@0.1mA$  for InGaN product and  $>1.4V@0.1mA$  for AlInGaP product.

## FR3535RGB4C-F2T

3.5x3.5mm, Intelligent control LED

PLCC-4 Package integrated light source



## Technical Data Sheet

---

### Terms and conditions for the usage of this document

1. The information included in this document reflects representative usage scenarios and is intended for technical reference only.
2. The part number, type, and specifications mentioned in this document are subject to future change and improvement without notice. Before production usage customer should refer to the latest datasheet for the updated specifications.
3. When using the products referenced in this document, please make sure the product is being operated within the environmental and electrical limits specified in the datasheet. If customer usage exceeds the specified limits, LuckyLight will not be responsible for any subsequent issues.
4. The information in this document applies to typical usage in consumer electronics applications. If customer's application has special reliability requirements or have life-threatening liabilities, such as automotive or medical usage, please consult with LuckyLight representative for further assistance.
5. The contents and information of this document may not be reproduced or re-transmitted without permission by LuckyLight.