

FV4020RGBC-F1J

4.0x2.0mm, Intelligent control LED

PLCC-4 Side Package integrated light source



Technical Data Sheet

Features:

FV4020 SIDE is a smart LED control circuit and light emitting circuit in one controlled LED source, which has the shape of a 4020 LED chip. Each lighting element is a pixel, and the intensities of the pixels are contained within the intelligent digital interface input. The output is driven by patented PWM technology, which effectively guarantees high consistency of the color of the pixels. The control circuit consists of a signal shaping amplification circuit, a built-in constant current circuit, and a high precision RC oscillator.

The data protocol being used is unipolar NRZ communication mode. The 24-bit data is transmitted from the controller to DIN of the first element, and if it is accepted it is extracted pixel to pixel. After an internal data latch, the remaining data is passed through the internal amplification circuit and sent out on the DO port to the remaining pixels. The pixel is reset after the end of DIN. Using automatic shaping forwarding technology makes the number of cascaded pixels without signal transmission only limited by signal transmission speed.

The LED has a low driving voltage (which allows for environmental protection and energy saving), high brightness, scattering angle, good consistency, low power, and long life. The control circuit is integrated in the LED above.

Applications:

- Full-color module, Full color soft lights a lamp strip.
- LED decorative lighting, Indoor/outdoor LED video irregular screen.

Part No.	Emitting Color		Lens Color
FV4020RGBC-F1J	R	Red	Water Clear
	G	Pure Green	
	B	Blue	

Spec No.: FV4020

Issue No.: G-Rev-4

LuckyLight Electronics Co., Ltd

Copyright © 2017 LuckyLight All Rights Reserved

Date: 28-Mar-2020

E-mail: sales@luckylight.cn

http:// www.luckylight.cn

Page: 1 / 10

FV4020RGB-C-F1J

4.0x2.0mm, Intelligent control LED

PLCC-4 Side Package integrated light source



Technical Data Sheet

Package Dimension:

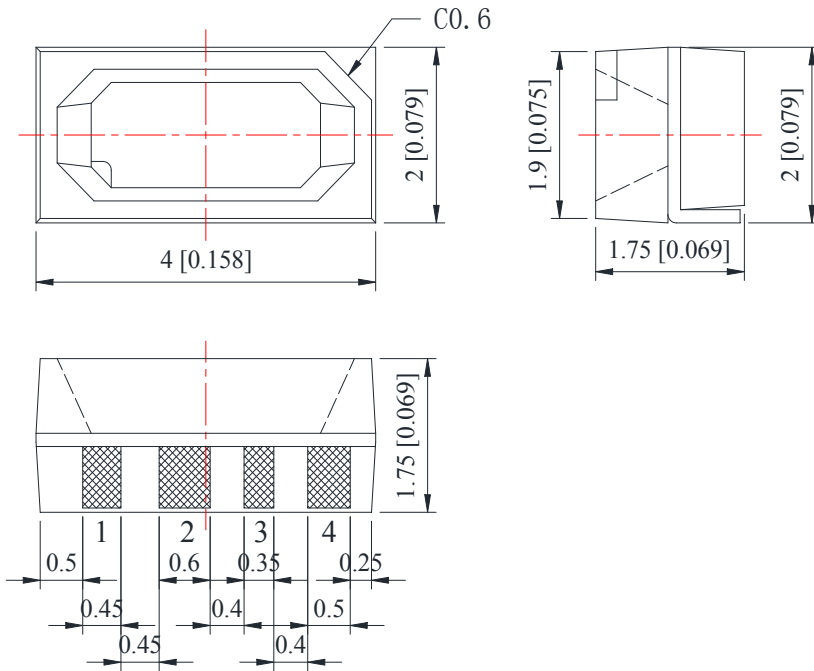

Pin Function

- 1 DIN: Control Data Signal Input
- 2 VDD: Power Supply LED
- 3 DOUT: Control Data Signal Output
- 4 VSS: Ground

PIN function:

NO.	Symbol	Function description
1	DIN	Control data signal input
2	VDD	Power supply LED
3	DOUT	Control data signal output
4	VSS	Ground

Notes:

1. All dimensions are in millimeters (inches).
2. Tolerance is ± 0.25 mm (.010") unless otherwise noted.
3. Protruded resin under flange is 1.00mm (.039") max.

FV4020RGB-C-F1J

4.0x2.0mm, Intelligent control LED

PLCC-4 Side Package integrated light source



Technical Data Sheet

Absolute Maximum Ratings at Ta=25°C

Parameter	Symbol	Ratings	Unit
Power supply voltage	VDD	+3.5~+5.5	V
Input voltage	VI	-0.5~VDD+0.4	V
Operation junction temperature	Topt	-25~+80	°C
Storage temperature range	Tstg	-40~+105	°C

Electrical Characteristics: (TA=-20~+70°C, VDD=4.5~5.5V, VSS=0V, unless otherwise specified)

Parameter	Symbol	conditions	Min	Tpy	Max	Unit
The chip supply voltage	VDD	—	—	5.0	—	v
Out R/G/B	VDS-s	IOUT=12MA	—	0.7	—	v
The frequency of PWM	FPWM	—	—	1.2	—	KHZ
Static power consumption	IDD	---	—	0.5	---	MA
DOUT drive capability	IDOH	DOUT connect ground, the maximum drive current	—	40	—	MA
	IDOL	DOUT connect +, the largest current	—	40	—	MA
The signal input flip threshold	VIH	VDD=5.0V	0.7	—	—	V
	VIL	VDD=5.0V	—	—	0.35	

Switching characteristics:

Parameter	Symbol	Condition	Min	Tpy	Max	Unit
The speed of data transmission	fDIN	The duty ratio of 67% (data 1)	—	800	—	KHZ
IOUT Rise/Drop Time	Tr	VDS=1.5	—	100	—	ns
	Tr	IOUT=12MA	—	100	—	ns
Input capacity	CI	—	—	—	15	pF
DOUT transmission delay	TPLH	DIN→DOUT	—	—	500	ns
	TPHL		—	—	500	ns

FV4020RGBC-F1J

4.0x2.0mm, Intelligent control LED

PLCC-4 Side Package integrated light source



Technical Data Sheet

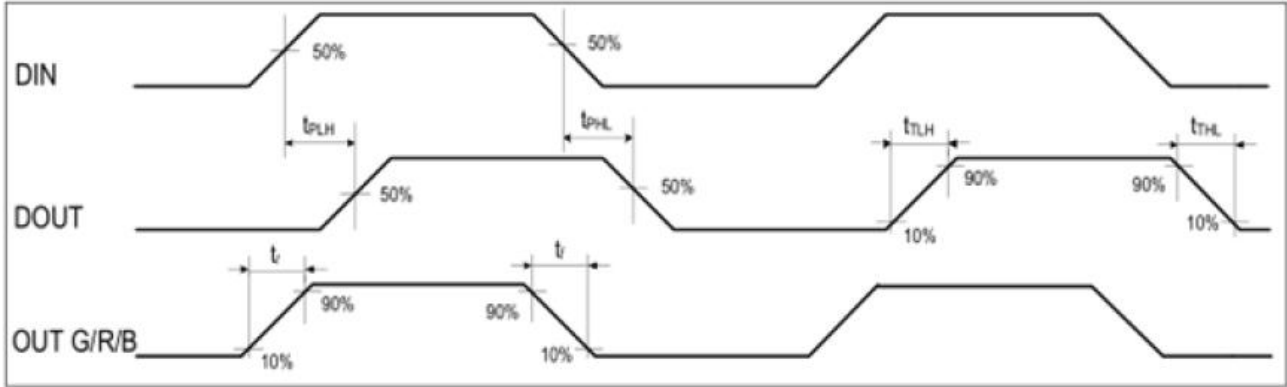

RGB IC characteristic parameter:

Emitting color	Model	Wavelength(nm)	Luminous intensity (mcd) Typ	Voltage(V)
Red	—	620-625	500	1.8-2.4
Green	—	520-525	1000	2.8-3.4
Blue	—	465-470	250	2.8-3.4

Data transfer time:(TH+TL=1.25μs±600ns)

T0H	0 code ,high voltage time	0.3us	±0.15μs
T1H	1 code ,high voltage time	0.9us	±0.15μs
T0L	0 code , low voltage time	0.9us	±0.15μs
T1L	1 code ,low voltage time	0.6us	±0.15μs
RES	low voltage time	Above 80μs	

Sequence chart:

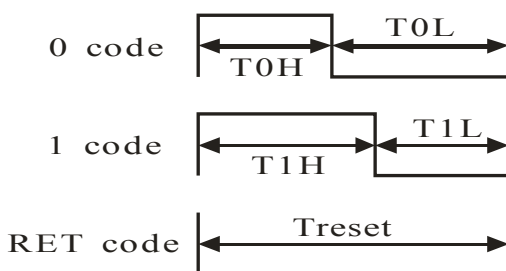

Cascade method:

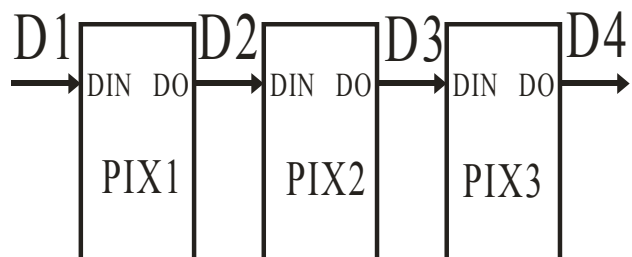

FV4020RGC-F1J

4.0x2.0mm, Intelligent control LED

PLCC-4 Side Package integrated light source



Technical Data Sheet

Data transmission method:

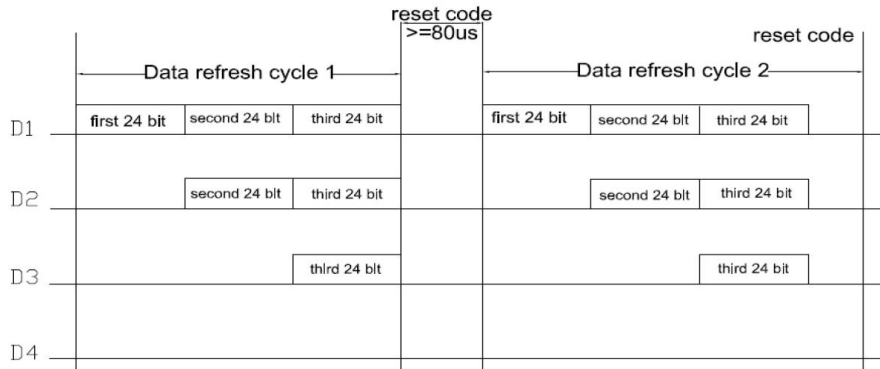

Note: The data of D1 is send by MCU, and D2, D3, D4 through pixel internal reshaping amplification to transmit.

Composition of 24bit data:

G7	G6	G5	G4	G3	G2	G1	G0	R7	R6	R5	R4	R3	R2	R1	R0	B7	B6	B5	B4	B3	B2	B1	B0
----	----	----	----	----	----	----	----	----	----	----	----	----	----	----	----	----	----	----	----	----	----	----	----

Note: Follow the order of GRB to sent data and the high bit sent at first.

Typical application circuit:

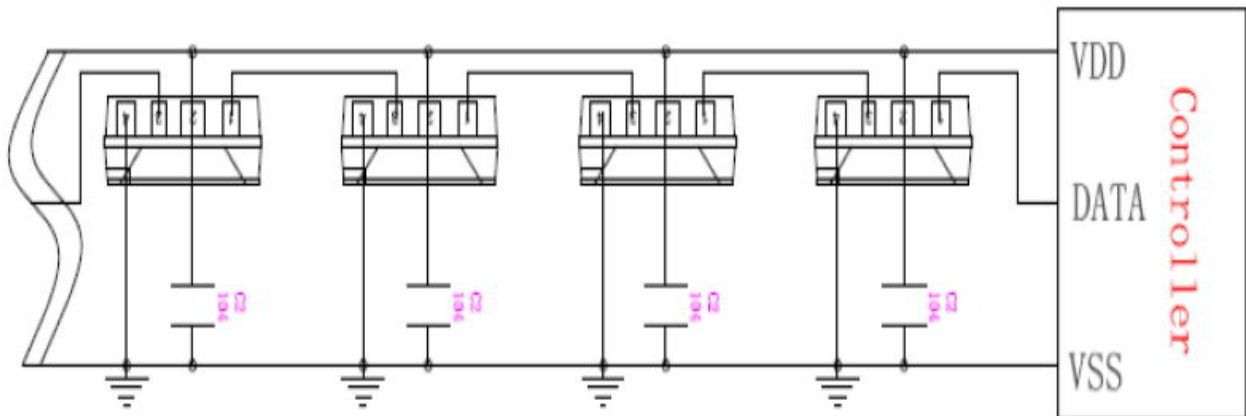

FV4020RGC-F1J

4.0x2.0mm, Intelligent control LED
PLCC-4 Side Package integrated light source



Technical Data Sheet

Reel Dimensions:

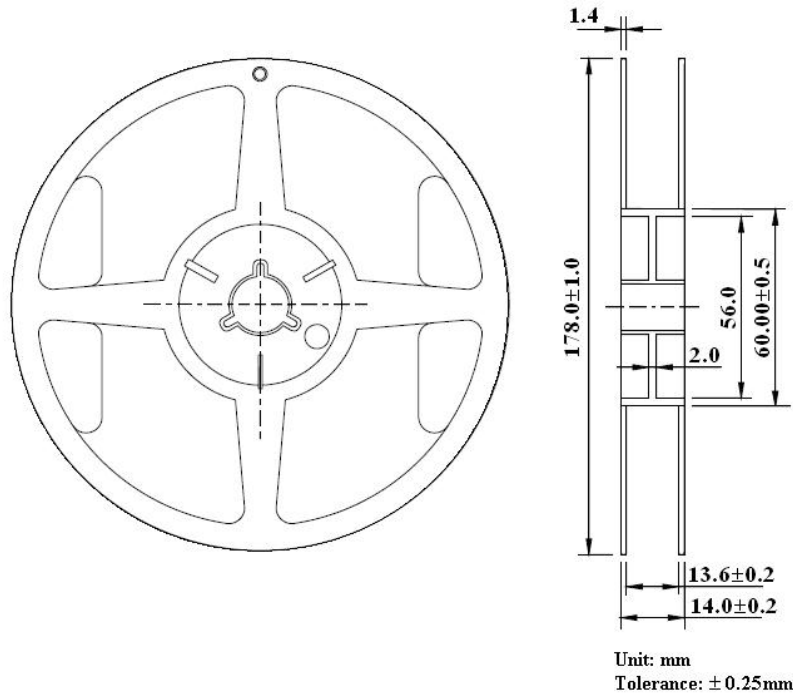

Carrier Tape Dimensions:

Loaded quantity 2000 pcs per reel.

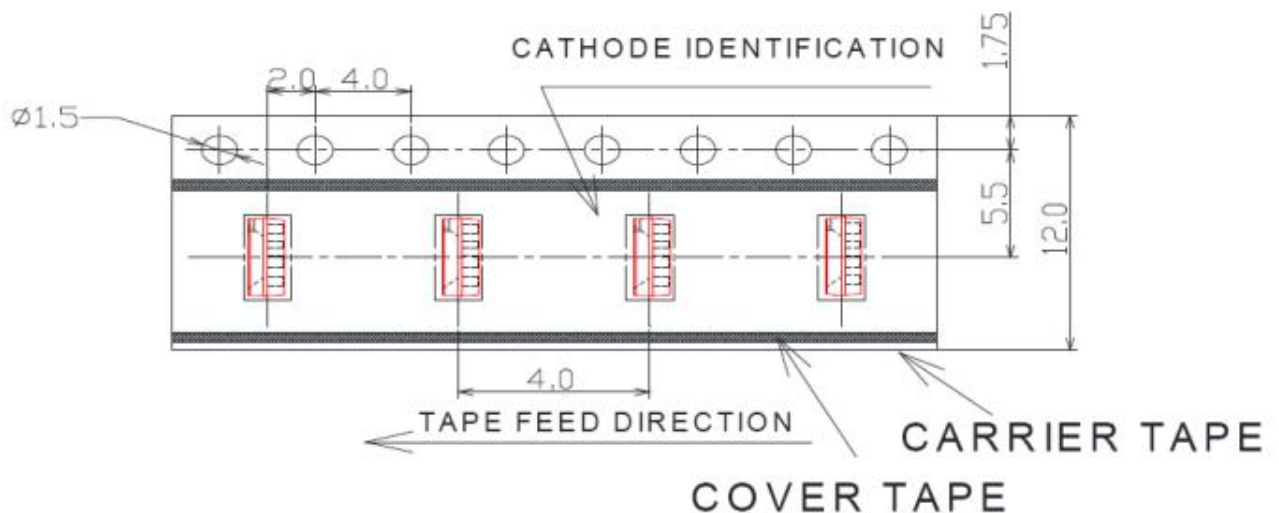

FV4020RGB-C-F1J

4.0x2.0mm, Intelligent control LED

PLCC-4 Side Package integrated light source

LuckyLight

Technical Data Sheet

CAUTIONS

1. Handling Precautions:

- 1.1. Handle the component along the side surfaces by using forceps or appropriate tools.
- 1.2. Do not directly touch or handle the silicone lens surface. It may damage the internal circuitry.
- 1.3. Do not stack together assembled PCBs containing exposed LEDs. Impact may scratch the silicone lens or damage the internal circuitry.

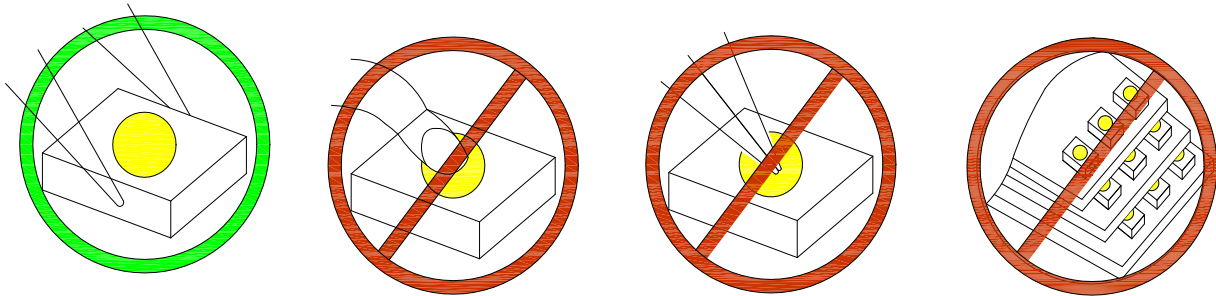

Compare to epoxy encapsulant that is hard and brittle, silicone is softer and flexible. Although its characteristic significantly reduces thermal stress, it is more susceptible to damage by external mechanical force. As a result, special handling precautions need to be observed during assembly using silicone encapsulated LED products. Failure to comply might lead to damage and premature failure of the LED.

2. Storage

- 2.1. Do not open moisture proof bag before the products are ready to use.
- 2.2. Before opening the package, the LEDs should be kept at 30°C or less and 60%RH or less.
- 2.3. The LEDs should be used within a year.
- 2.4. After opening the package, the LEDs should be kept at 30°C or less and 60%RH or less.
- 2.5. The LEDs should be used within 24 hours after opening the package.
- 2.6. If the moisture adsorbent material has fabled away or the LEDs have exceeded the storage time, baking treatment should be performed using the following conditions. Baking treatment: 65±5°C for 24 hours.

3. Soldering Condition

Spec No.: FV4020

Issue No.: G-Rev-4

LuckyLight Electronics Co., Ltd

Copyright © 2017 LuckyLight All Rights Reserved

Date: 28-Mar-2020

E-mail: sales@luckyLight.cn

http:// www.luckyLight.cn

Page: 7 / 10

FV4020RGBC-F1J

4.0x2.0mm, Intelligent control LED

PLCC-4 Side Package integrated light source



Technical Data Sheet

3.1. Pb-free solder temperature profile

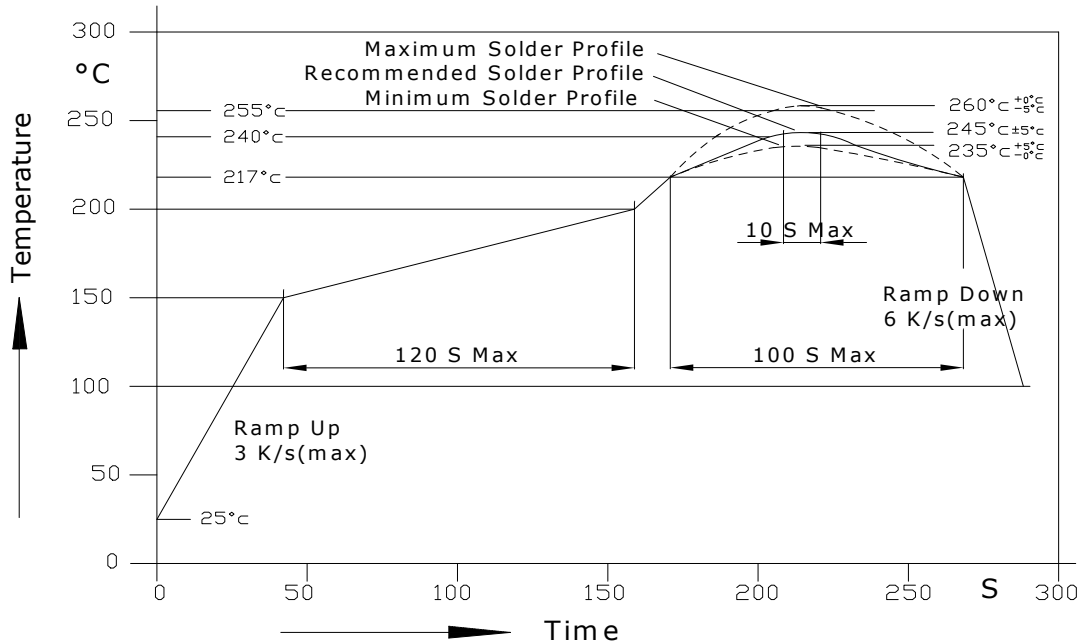

3.2. Reflow soldering should not be done more than two times.

3.3. When soldering, do not put stress on the LEDs during heating.

3.4. After soldering, do not warp the circuit board.

3.5. Recommended soldering conditions:

Reflow soldering		Soldering iron	
Pre-heat	150~200°C	Temperature	300°C Max.
Pre-heat time	120 sec. Max.	Soldering time	3 sec. Max.
Peak temperature	250°C Max.		(one time only)
Soldering time	10 sec. Max.(Max. two times)		

3.6. Because different board designs use different number and types of devices, solder pastes, reflow ovens, and circuit boards, no single temperature profile works for all possible combinations.

However, you can successfully mount your packages to the PCB by following the proper guidelines and PCB-specific

FV4020RGB-C-F1J

4.0x2.0mm, Intelligent control LED

PLCC-4 Side Package integrated light source

LuckyLight

Technical Data Sheet

characterization.

4. Drive Method

4.1. An LED is a current-operated device. In order to ensure intensity uniformity on multiple LEDs connected in parallel in an application, it is recommended that a current limiting resistor be incorporated in the drive circuit, in series with each LED as shown in Circuit A below.

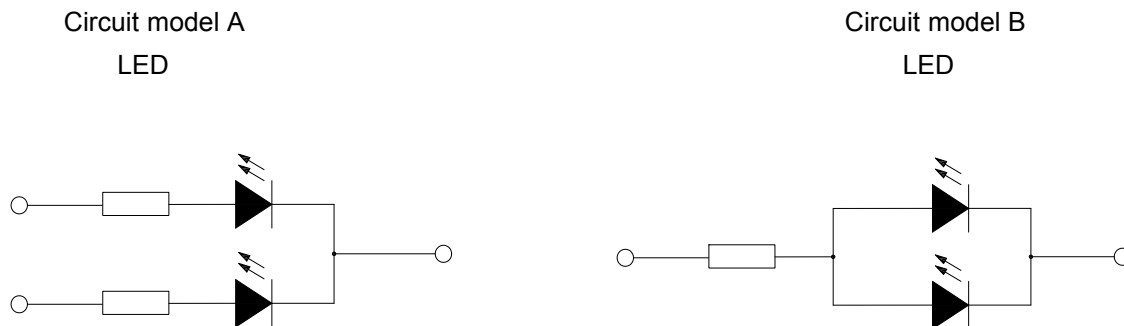

a. Recommended circuit.

b. The brightness of each LED might appear different due to the differences in the I-V characteristics of those LEDs.

5. ESD (Electrostatic Discharge):

Static Electricity or power surge will damage the LED. Suggestions to prevent ESD damage:

- Use of a conductive wrist band or anti-electrostatic glove when handling these LEDs.
- All devices, equipment, and machinery must be properly grounded.
- Work tables, storage racks, etc. should be properly grounded.
- Use ion blower to neutralize the static charge which might have built up on surface of the LED's plastic lens as a result of friction between LEDs during storage and handling.

ESD-damaged LEDs will exhibit abnormal characteristics such as high reverse leakage current, low forward voltage, or "no lightup" at low currents. To verify for ESD damage, check for "lightup" and V_f of the suspect LEDs at low currents. The V_f of "good" LEDs should be $>2.0V@0.1mA$ for InGaN product and $>1.4V@0.1mA$ for AlInGaP product.

Terms and conditions for the usage of this document

Spec No.: FV4020

Issue No.: G-Rev-4

LuckyLight Electronics Co., Ltd

Copyright © 2017 LuckyLight All Rights Reserved

Date: 28-Mar-2020

E-mail: sales@luckyLight.cn

http:// www.luckyLight.cn

Page: 9 / 10

FV4020RGB-C-F1J

4.0x2.0mm, Intelligent control LED

PLCC-4 Side Package integrated light source



Technical Data Sheet

1. The information included in this document reflects representative usage scenarios and is intended for technical reference only.
2. The part number, type, and specifications mentioned in this document are subject to future change and improvement without notice. Before production usage customer should refer to the latest datasheet for the updated specifications.
3. When using the products referenced in this document, please make sure the product is being operated within the environmental and electrical limits specified in the datasheet. If customer usage exceeds the specified limits, LuckyLight will not be responsible for any subsequent issues.
4. The information in this document applies to typical usage in consumer electronics applications. If customer's application has special reliability requirements or have life-threatening liabilities, such as automotive or medical usage, please consult with LuckyLight representative for further assistance.
5. The contents and information of this document may not be reproduced or re-transmitted without permission by LuckyLight.