

# FR5050RGB4C-F1T-AW

5.5x5.0mm, Intelligent control LED  
PLCC-4 Package integrated light source

## Technical Data Sheet

---

### Features

- PLCC-4 package.
- Intelligent reverse connect protection, the power supply reverse connection does not damage the IC.
- The control circuit and the LED share the only power source.
- Control circuit and RGB chip are integrated in a package of 5050 components, form a complete control of pixel point.
- Built-in signal reshaping circuit, after wave reshaping to the next driver, ensure wave-form distortion not accumulate.
- Built-in electric reset circuit and power lost reset circuit.
- Each pixel of the three primary color can achieve 256 brightness display, completed 16777216 color full color display, and scan frequency not less than 400Hz/s.
- Cascading port transmission signal by single line.
- Any two point the distance more than 5m transmission signal without any increase circuit.
- When the refresh rate is 30fps, cascade number are not less than 1024 points.
- Send data at speeds of 800Kbps.

### Applications

- Full-color module, Full color soft lights a lamp strip.
- LED decorative lighting, Indoor/outdoor LED video irregular screen.

Part No.	Emitting Color		Lens Color
FR5050RGB4C-F1T-AW	R	Red	Water Clear
	G	Pure Green	
	B	Blue	

# FR5050RGB4C-F1T-AW

5.5x5.0mm, Intelligent control LED  
PLCC-4 Package integrated light source

## Technical Data Sheet

### Package Dimension

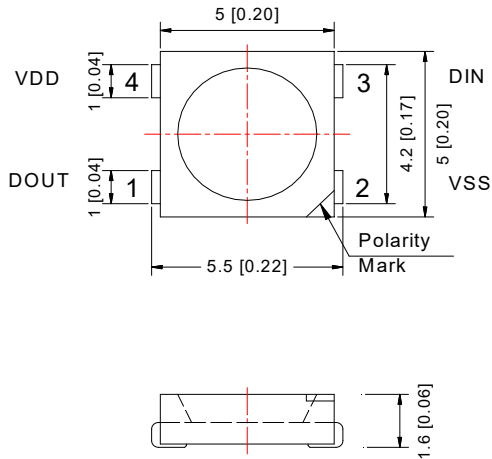

### Pin Function

- 1 DOUT: Control Data Signal Output
- 2 VSS: Ground
- 3 DIN: Control Data Signal Input
- 4 VDD: Power Supply LED

### Recommended Soldering Pad dimensions

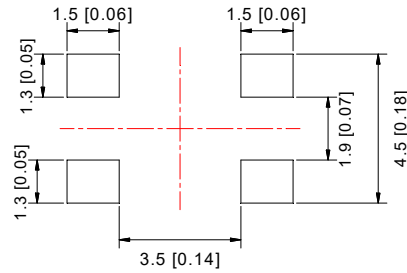
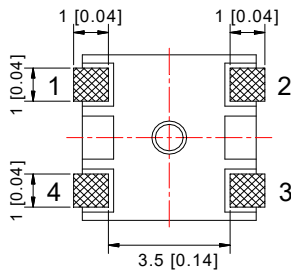

### PIN function

NO.	Symbol	Function description
1	DOUT	Control data signal output
2	VSS	Ground
3	DIN	Control data signal input
4	VDD	Power supply LED

### Notes:

- 1. All dimensions are in millimeters (inches).
- 2. Tolerance is  $\pm 0.25$  mm (.010") unless otherwise noted.

# FR5050RGB4C-F1T-AW

5.5x5.0mm, Intelligent control LED  
PLCC-4 Package integrated light source

## Technical Data Sheet

### Absolute Maximum Ratings at Ta=25°C

Parameter	Symbol	Ratings	Unit
Power supply voltage	VDD	+3.5~+5.5	V
Input voltage	VI	-0.5~VDD+5.5	V
Operation junction temperature	Topt	-40~+85	°C
Storage temperature range	Tstg	-40~+105	°C

### Electrical Characteristics: (TA=-20~+70°C, VDD=4.5~5.5V, VSS=0V, unless otherwise specified)

Parameter	Symbol	conditions	Min	Tpy	Max	Unit
Input current	II	VI=VDD/VSS	—	—	±1	μA
Input voltage level	VIH	DIN, SET	0.7*VDD	—	—	V
	VIL	DIN, SET	—	—	0.3* VDD	V
R/G/B Output port withstand voltage	Vds	—	8.5	9.0	9.5	V
PWM	FPWM	—	3	4	5	KHZ
Static power consumption	IDD	—	0.6	0.8	1	mA
Voltage of power supply in chip	VDD	—	—	5.0	—	V
LoI1	RGB Output current	—	—	12	—	mA

### Switching characteristics

Parameter	Symbol	Condition	Min	Tpy	Max	Unit
Transmission delay time	tPLZ	DIN→DOUT	—	—	200	ns
Data transmission speed	fDIN	—	—	800	1100	KHZ
Iout	Tf	VDS=1.5V T IOU=12mA	—	—	400	ns
	Tr		—	—	400	ns

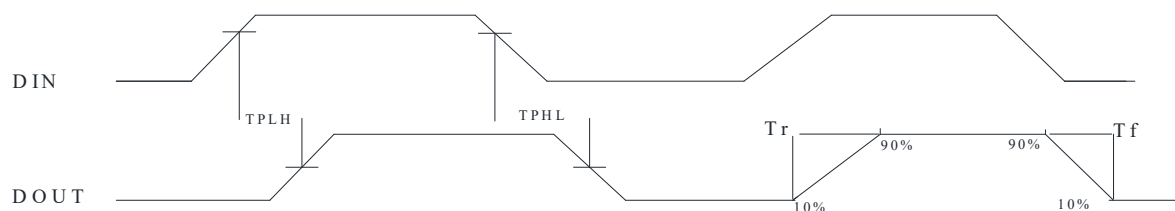

# FR5050RGB4C-F1T-AW

5.5x5.0mm, Intelligent control LED  
PLCC-4 Package integrated light source

## Technical Data Sheet

### RGB IC characteristic parameter

Emitting color	Wavelength (nm)	Luminous intensity (mcd)	Conditions (mA)
Red	620-630	200-400	12
Green	520-530	700-1000	12
Blue	465-475	150-300	12

### Data transfer time

Timetable name		Min.	Tpy	Max	Unit
T0H	0 code ,high voltage time	200	300	400	ns
T0L	0 code , low voltage time	550	600	1050	ns
T1H	1 code ,high voltage time	550	600	1050	ns
T1L	1 code ,low voltage time	200	300	400	ns
RES	low voltage time	>80	--	--	us

### Sequence chart

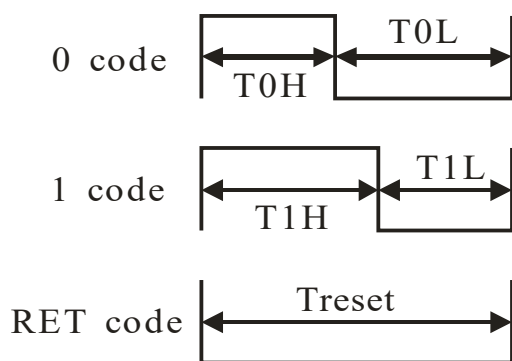

### Cascade method

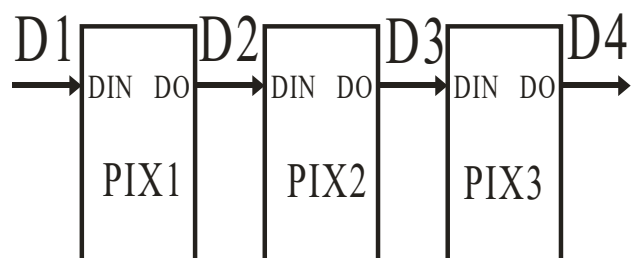

# FR5050RGB4C-F1T-AW

5.5x5.0mm, Intelligent control LED  
PLCC-4 Package integrated light source

## Technical Data Sheet

### Data transmission method

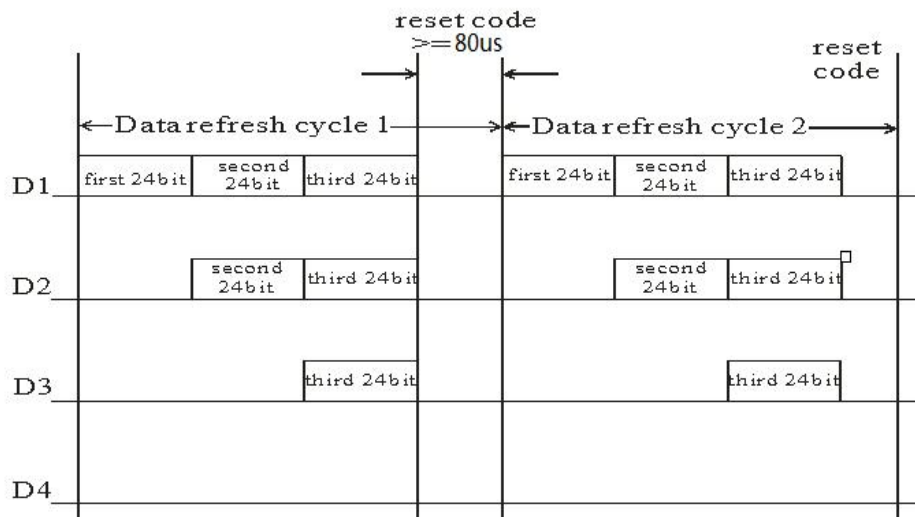

Note: The data of D1 is sent by MCU, and D2, D3, D4 through pixel internal reshaping amplification to transmit.

### Composition of 24bit data

G7	G6	G5	G4	G3	G2	G1	G0	R7	R6	R5	R4	R3	R2	R1	R0	B7	B6	B5	B4	B3	B2	B1	B0
----	----	----	----	----	----	----	----	----	----	----	----	----	----	----	----	----	----	----	----	----	----	----	----

Note: Follow the order of GRB to sent data and the high bit sent at first.

### Typical application circuit

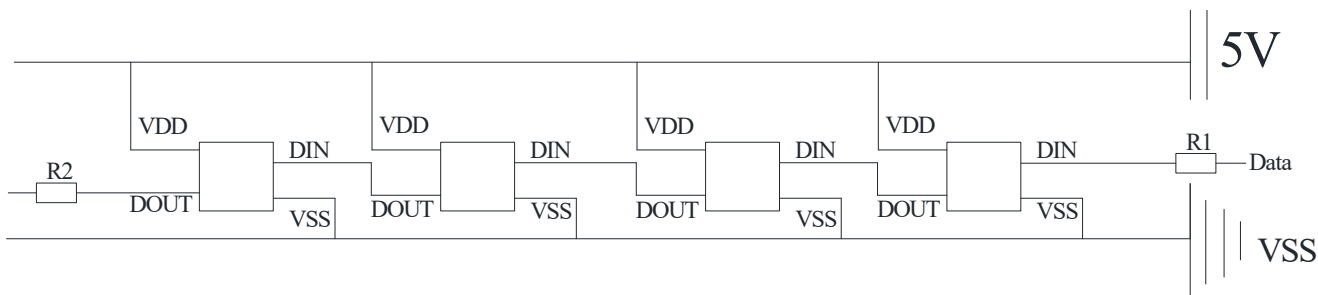

# FR5050RGB4C-F1T-AW

5.5x5.0mm, Intelligent control LED  
PLCC-4 Package integrated light source

## Technical Data Sheet

### Reel Dimensions

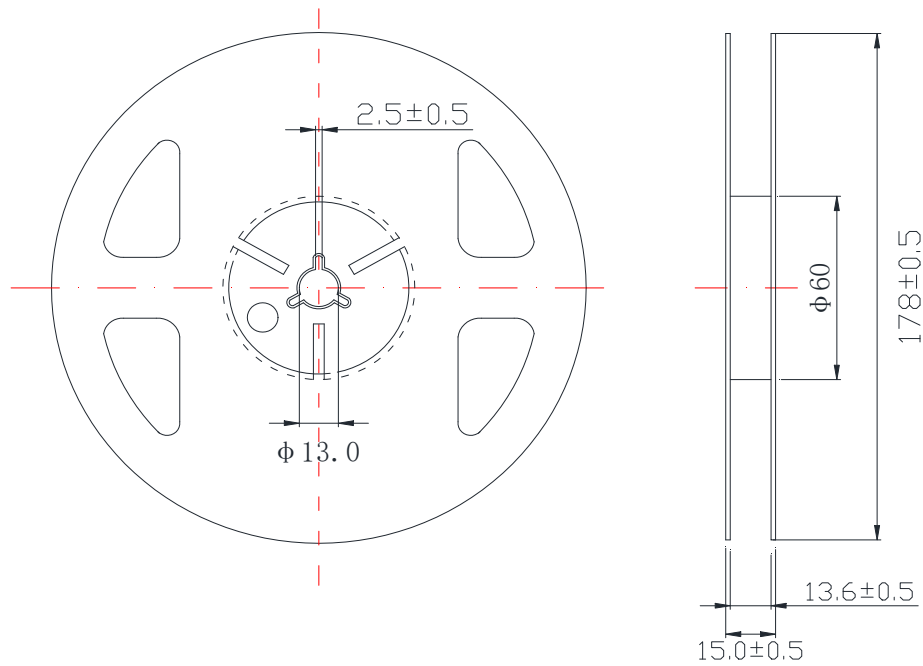

### Carrier Tape Dimensions

Loaded quantity 1000 pcs per reel.

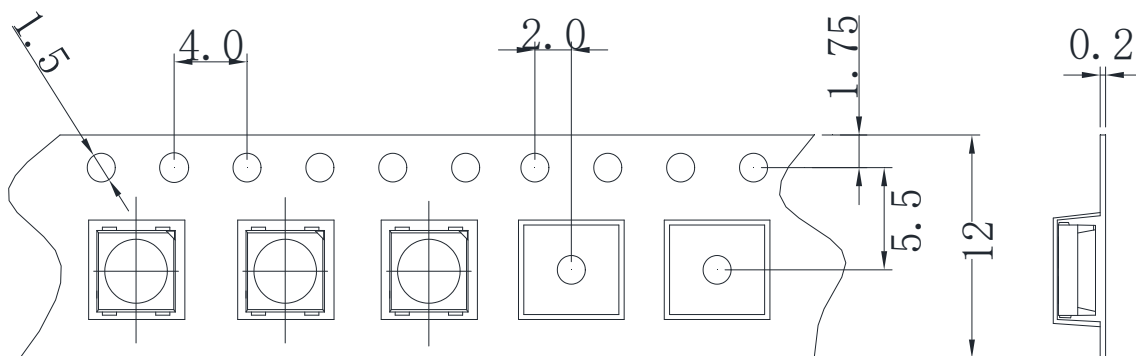

# FR5050RGB4C-F1T-AW

5.5x5.0mm, Intelligent control LED

PLCC-4 Package integrated light source

## Technical Data Sheet

### CAUTIONS

#### 1. Handling Precautions:

- 1.1. Handle the component along the side surfaces by using forceps or appropriate tools.
- 1.2. Do not directly touch or handle the silicone lens surface. It may damage the internal circuitry.
- 1.3. Do not stack together assembled PCBs containing exposed LEDs. Impact may scratch the silicone lens or damage the internal circuitry.

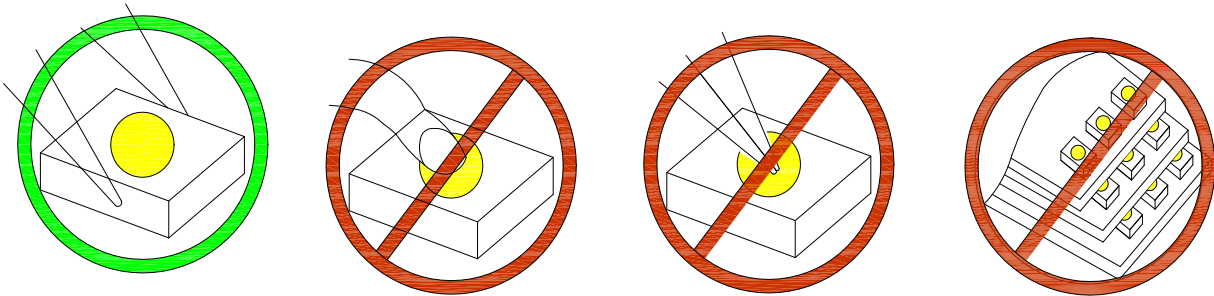

Compare to epoxy encapsulant that is hard and brittle, silicone is softer and flexible. Although its characteristic significantly reduces thermal stress, it is more susceptible to damage by external mechanical force. As a result, special handling precautions need to be observed during assembly using silicone encapsulated LED products. Failure to comply might lead to damage and premature failure of the LED.

#### 2. Storage

- 2.1. Do not open moisture proof bag before the products are ready to use.
- 2.2. Before opening the package, the LEDs should be kept at 30°C or less and 60%RH or less.
- 2.3. The LEDs should be used within a year.
- 2.4. After opening the package, the LEDs should be kept at 30°C or less and 60%RH or less.
- 2.5. The LEDs should be used within 24 hours after opening the package.
- 2.6. If the moisture adsorbent material has fabled away or the LEDs have exceeded the storage time, baking treatment should be performed using the following conditions. Baking treatment: 65±5°C for 24 hours.

#### 3. Soldering Condition

Spec No.: FR5050

Issue No.: G-Rev-4

LuckyLight Electronics Co., Ltd

Copyright © 2023 LuckyLight All Rights Reserved

Date: 12-Mar-2023

E-mail: sales@luckyLight.cn

http:// www.luckyLight.cn

Page: 7 / 10

**Technical Data Sheet**

3.1. Pb-free solder temperature profile

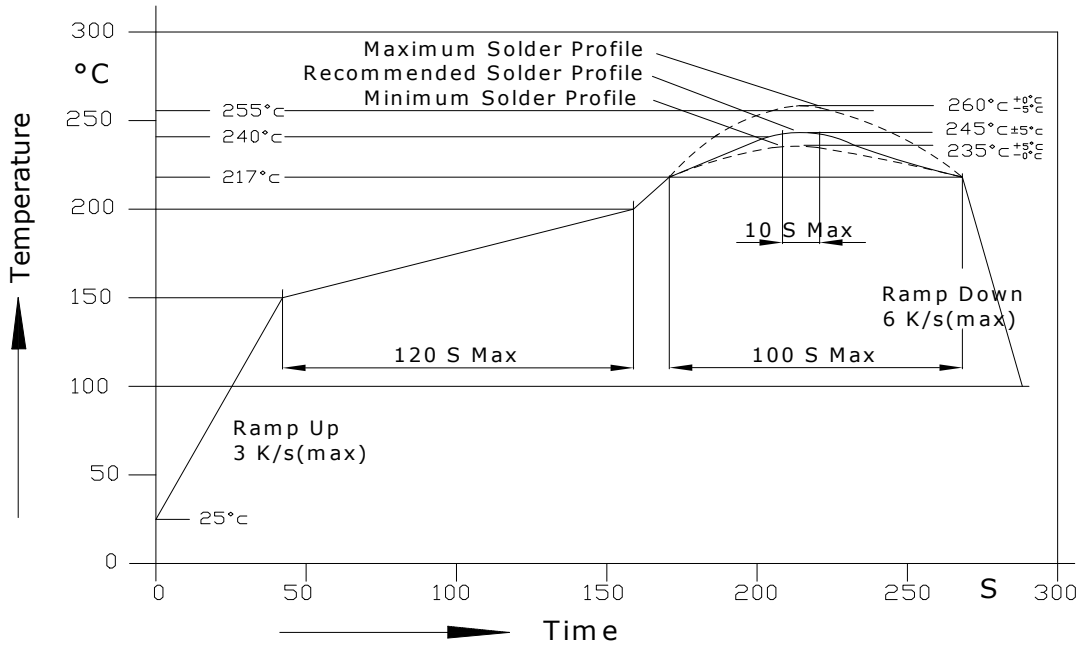

- 3.2. Reflow soldering should not be done more than two times.
- 3.3. When soldering, do not put stress on the LEDs during heating.
- 3.4. After soldering, do not warp the circuit board.
- 3.5. Recommended soldering conditions:

Reflow soldering		Soldering iron	
Pre-heat	150~200°C	Temperature	300°C Max.
Pre-heat time	120 sec. Max.	Soldering time	3 sec. Max.
Peak temperature	250°C Max.		(one time only)
Soldering time	10 sec. Max.(Max. two times)		

3.6. Because different board designs use different number and types of devices, solder pastes, reflow ovens, and circuit boards, no single temperature profile works for all possible combinations.

However, you can successfully mount your packages to the PCB by following the proper guidelines and PCB-specific

# FR5050RGB4C-F1T-AW

5.5x5.0mm, Intelligent control LED

PLCC-4 Package integrated light source

## Technical Data Sheet

---

characterization.

### 4. Drive Method

4.1. An LED is a current-operated device. In order to ensure intensity uniformity on multiple LEDs connected in parallel in an application, it is recommended that a current limiting resistor be incorporated in the drive circuit, in series with each LED as shown in Circuit A below.

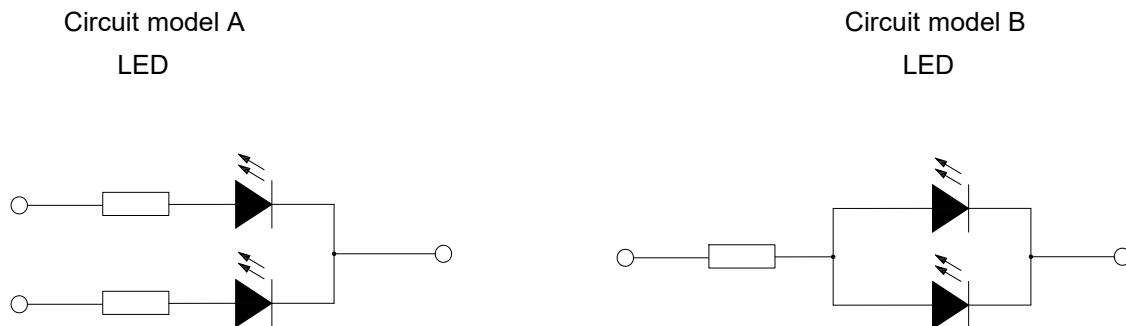

- a. Recommended circuit.
- b. The brightness of each LED might appear different due to the differences in the I-V characteristics of those LEDs.

### 5. ESD (Electrostatic Discharge):

Static Electricity or power surge will damage the LED. Suggestions to prevent ESD damage:

- Use of a conductive wrist band or anti-electrostatic glove when handling these LEDs.
- All devices, equipment, and machinery must be properly grounded.
- Work tables, storage racks, etc. should be properly grounded.
- Use ion blower to neutralize the static charge which might have built up on surface of the LED's plastic lens as a result of friction between LEDs during storage and handling.

ESD-damaged LEDs will exhibit abnormal characteristics such as high reverse leakage current, low forward voltage, or “no lightup” at low currents. To verify for ESD damage, check for “lightup” and Vf of the suspect LEDs at low currents. The Vf of “good” LEDs should be >2.0V@0.1mA for InGaN product and >1.4V@0.1mA for AllnGaP product.

# FR5050RGB4C-F1T-AW

5.5x5.0mm, Intelligent control LED

PLCC-4 Package integrated light source

LuckyLight

## Technical Data Sheet

---

### Terms and conditions for the usage of this document

1. The information included in this document reflects representative usage scenarios and is intended for technical reference only.
2. The part number, type, and specifications mentioned in this document are subject to future change and improvement without notice. Before production usage customer should refer to the latest datasheet for the updated specifications.
3. When using the products referenced in this document, please make sure the product is being operated within the environmental and electrical limits specified in the datasheet. If customer usage exceeds the specified limits, LuckyLight will not be responsible for any subsequent issues.
4. The information in this document applies to typical usage in consumer electronics applications. If customer's application has special reliability requirements or have life-threatening liabilities, such as automotive or medical usage, please consult with LuckyLight representative for further assistance.
5. The contents and information of this document may not be reproduced or re-transmitted without permission by LuckyLight.