

**Technical Data Sheet**

---

**Features**

- High reliability
- Low current operation
- Low profile and light weight (for space-saving designs)
- Packaged in tape and reel for automated SMT assembly
- Compatible with IR-reflow soldering
- Excellent character appearance
- RoHS compliant



**Descriptions**

KD4-S561AAB (Common Anode) and KD4-S561CAB (Common Cathode) are 0.56-inch (14.20 mm) character height surface-mount (SMD) orange 4-digit seven-segment displays. These devices provide excellent readability at distances up to 7 meters and offer stable performance under high ambient light conditions. The standard version features a black surface with white segments; a gray surface version is also available as an option.

**Applications**

**Consumer Electronics:** Home appliances, Game console systems

**Commercial Terminals:** Point-of-sale terminals

**General Use:** Digital readout displays

**Industrial Equipment:** Instrumentation panels, Test and measurement equipment, Control systems

**Device Selection Guide**

Part No.	Emitting Color	Circuit Type
KD4-S561AAB	Orange	Common Anode
KD4-S561CAB	Orange	Common Cathode

**Technical Data Sheet**

**Package Dimension**

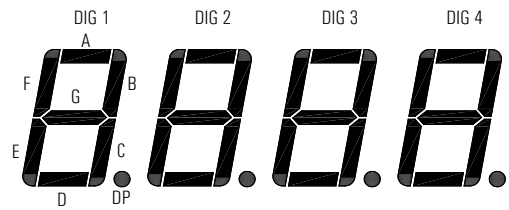
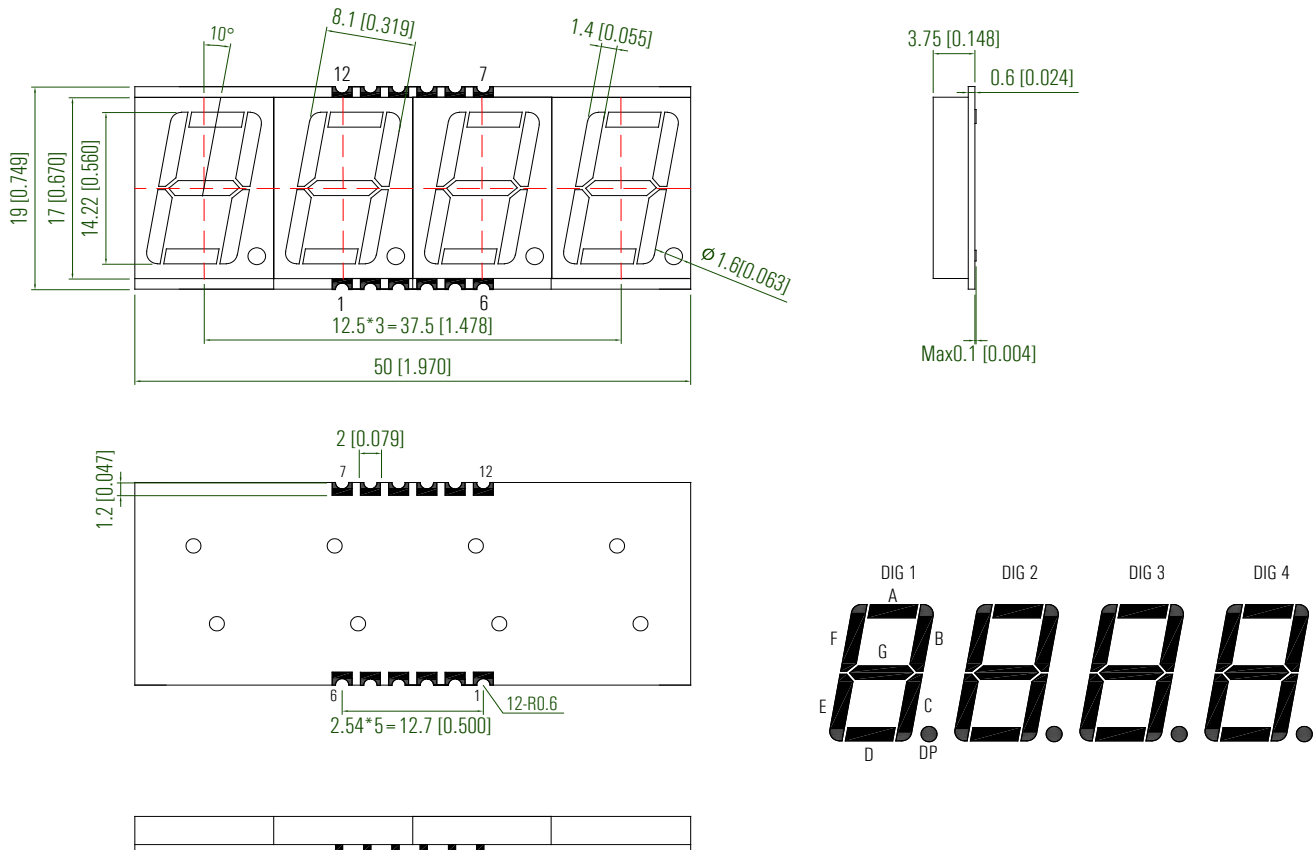

**Notes:**

1. All dimensions are in millimeters (inches).
2. Tolerance is  $\pm 0.25$  mm (.010") unless otherwise noted.
3. The gap between the reflector and PCB shall not exceed 0.25mm.

**Technical Data Sheet**

**Internal Circuit Diagram:**

**KD4-S561AAB (Common Anode)**

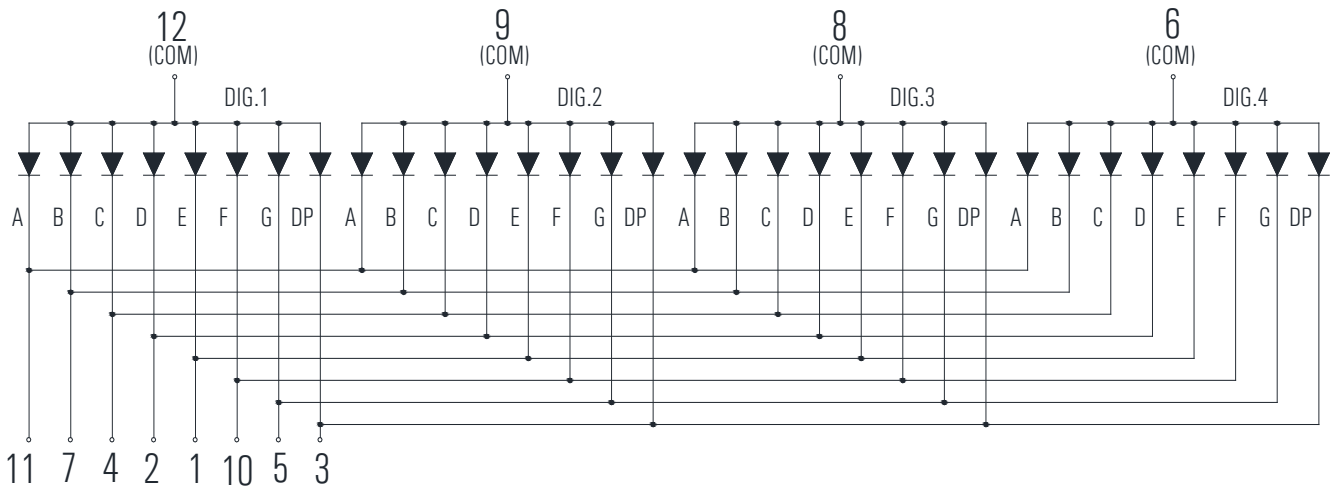

**KD4-S561CAB (Common Cathode)**

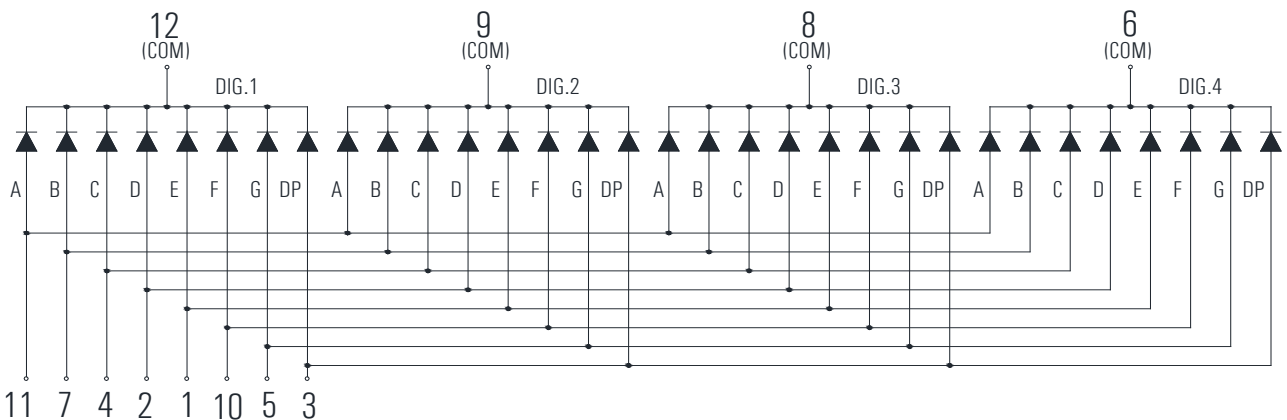

**0.56-inch (14.20 mm) 4-Digit Seven-Segment Display**  
**Orange Surface-Mount Four-Digit LED Numeric Display**

**Technical Data Sheet**

**Pin Connection**

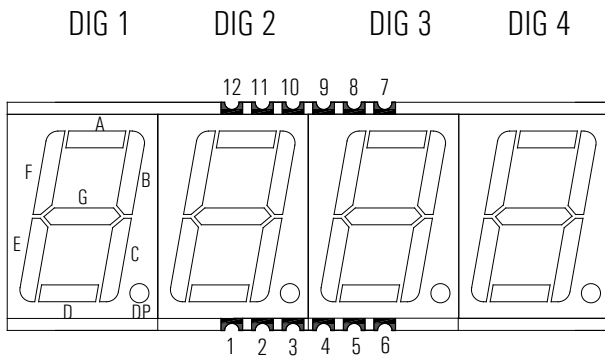

Pin No.	Function
1	Segment E
2	Segment D
3	Segment DP
4	Segment C
5	Segment G
6	Digit4 Common
7	Segment B
8	Digit3 Common
9	Digit2 Common
10	Segment F
11	Segment A
12	Digit1 Common

**Recommended Soldering Pattern**

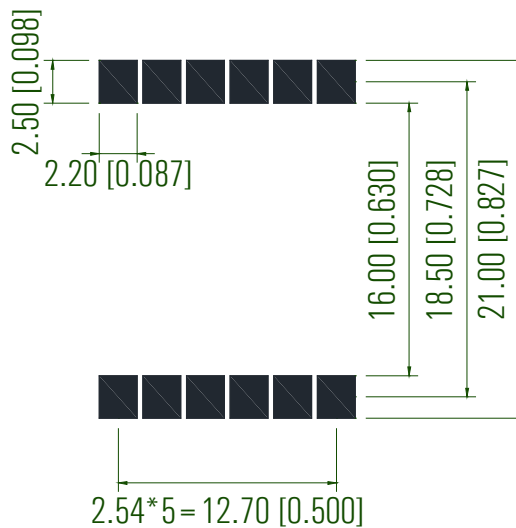

**0.56-inch (14.20 mm) 4-Digit Seven-Segment Display**  
**Orange Surface-Mount Four-Digit LED Numeric Display**
**Technical Data Sheet**
**Absolute Maximum Ratings at  $T_a=25^\circ\text{C}$** 

Parameters	Symbol	Max	Unit
Power Dissipation (Per Chip)	$P_d$	48	mW
Peak Forward Current (Per Segment) (1/10 Duty Cycle, 0.1ms pulse width)	$I_{FP}$	40	mA
Forward Current (Per Segment)	$I_F$	20	mA
Reverse Voltage (Per Chip)	$V_R$	5	V
Operating Temperature Range	$T_{opr}$	-40°C to +80°C	
Storage Temperature Range	$T_{stg}$	-40°C to +85°C	
Soldering Temperature	$T_{sld}$	260°C for 5 Seconds	

**Electrical Optical Characteristics at  $T_a=25^\circ\text{C}$** 

Parameters	Symbol	Min.	Typ.	Max.	Unit	Test Condition
Average Luminous Intensity	$I_v$	5.5	11.0	---	mcd	IF=5mA (Note a)
		11.0	22.0	---	mcd	IF=10mA (Note a)
Luminous Intensity Matching Ratio	$I_{v-m}$	---	---	2:1		IF=20mA
Peak Emission Wavelength	$\lambda_p$	---	610	---	nm	IF=20mA
Dominant Wavelength	$\lambda_d$	---	605	---	nm	IF=20mA (Note b)
Spectral Line Half-Width	$\Delta\lambda$	---	20	---	nm	IF=20mA
Forward Voltage (Per Segment)	$V_F$	---	2.0	2.4	V	IF=20mA (Note c)
Reverse Current (Per Segment)	$I_R$	---	---	50	$\mu\text{A}$	VR=5V

**Notes:**

- Luminous intensity is measured with a light sensor and filter combination that approximates the CIE eye-response curve.  
Tolerance of Luminous Intensity:  $\pm 10\%$
- The dominant wavelength ( $\lambda_d$ ) is derived from the CIE chromaticity diagram and represents the single wavelength which defines the color of the device.
- Tolerance of Forward Voltage:  $\pm 0.1V$

**Technical Data Sheet**

**Typical Electrical/Optical Characteristics Curves (T<sub>a</sub>=25 °C)**

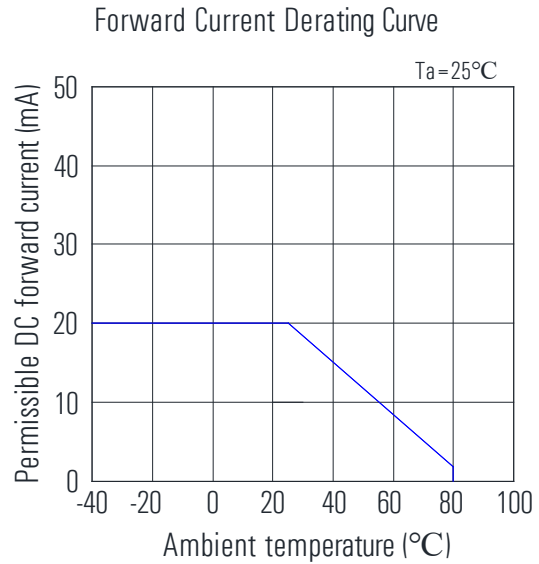
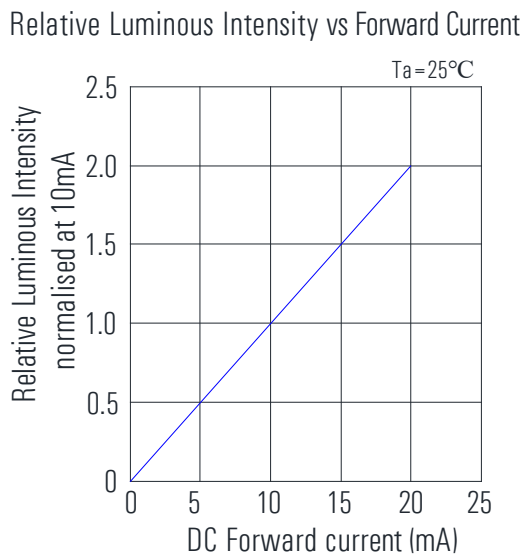
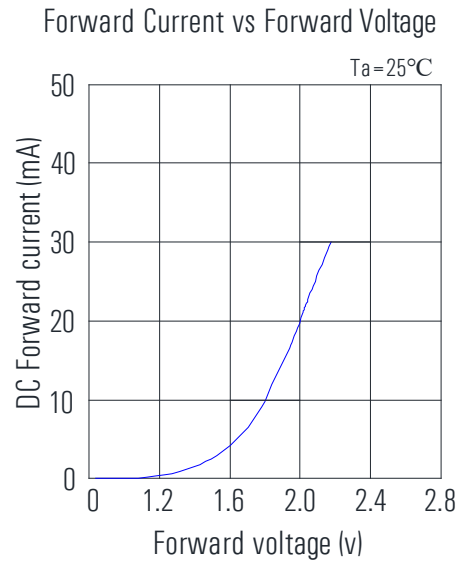
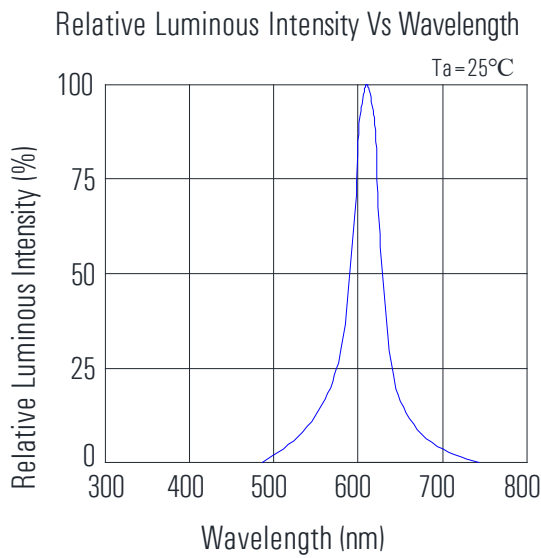

**Technical Data Sheet**

---

**Reel Dimensions (units: mm)**

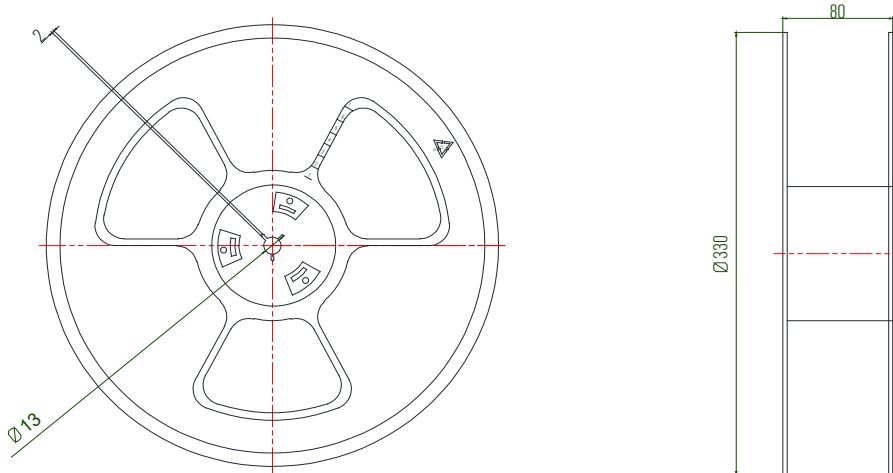

**Tape Specifications (units: mm):**

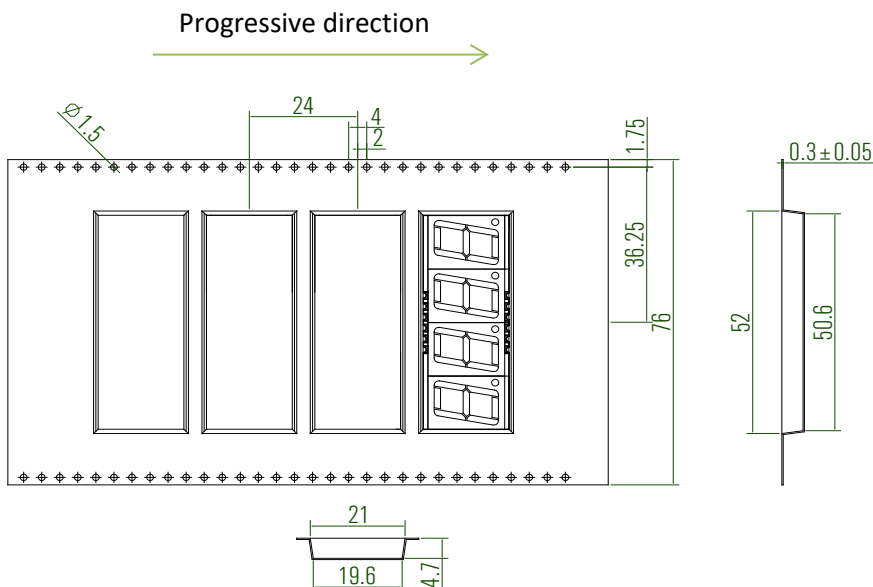

Note: Tolerances unless mentioned  $\pm 0.25\text{mm}$ .

**Technical Data Sheet**

---

**Packing & Label Specifications**

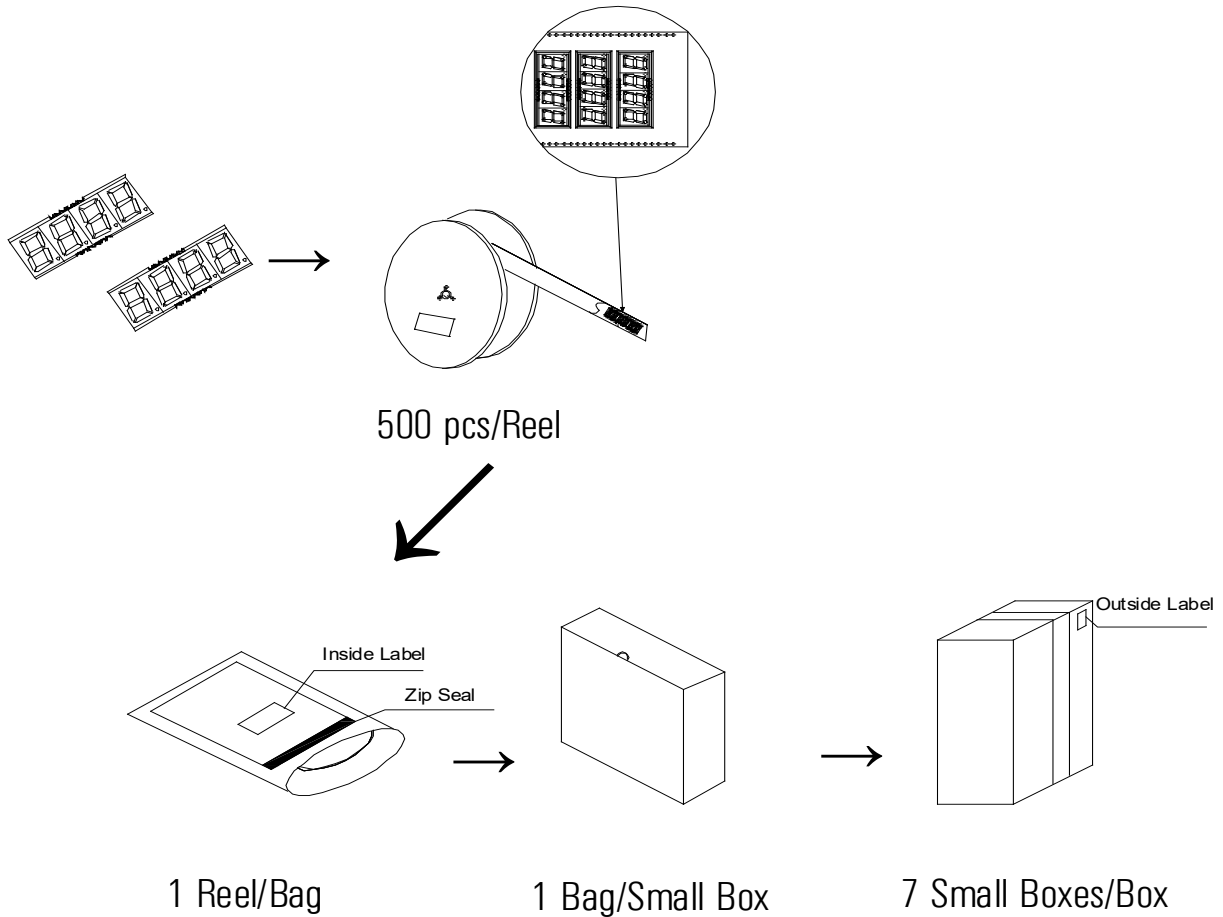

**0.56-inch (14.20 mm) 4-Digit Seven-Segment Display**  
**Orange Surface-Mount Four-Digit LED Numeric Display**

**Technical Data Sheet**

**Precautions for Use**

**1. Pb-Free Reflow Soldering Profile.**

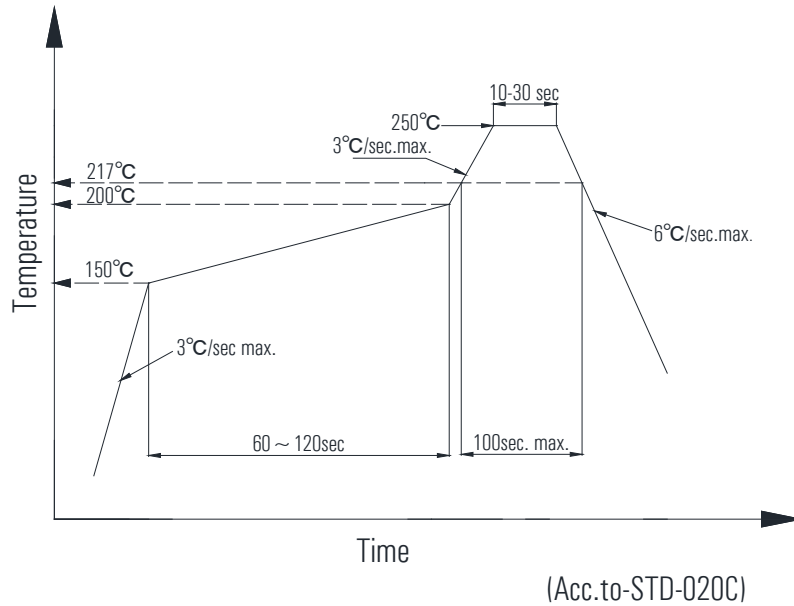

Pre-heat		Other	
Temperature min	150 °C	Liquidus Temperature	217°C
Temperature max	200 °C	Time above Liquidus Temperature	100sec.max
Time	60-120sec	Peak Temperature	250°C
Average ramp-up rate	3 °C/sec.max.	Ramp- Down Rate from Peak Temperature	6 °C/sec. max.
		Reflow times	1 time

- a. Reflow soldering is recommended. Other soldering methods are not recommended as they might cause damage to the product.
- b. All parameters are maximum body case temperature values and cannot be considered as a soldering profile. The body case temperature was measured by soldering a thermal couple to the soldering point of LEDs.
- c. No more than one reflows welding is recommended.

## Technical Data Sheet

---

### 2. Circuit Design Notes:

- Protective current-limiting resistors may be necessary to operate the LEDs within the specified range.
- LEDs mounted in parallel should each be placed in series with its own current-limiting resistor.
- The driving circuit should be designed to protect the LED against reverse voltages and transient voltage spikes when the circuit is powered up or shut down.
- The safe operating current should be chosen after considering the maximum ambient temperature of the operating environment.

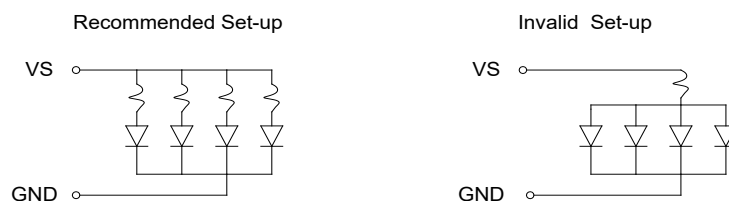

### Terms and Conditions for Product Usage

- Technical Reference:** The information included in this document reflects representative usage scenarios and is intended for technical reference only.
- Specification Changes:** Part numbers, types, and specifications are subject to change or improvement without notice. Customers should verify the latest specifications with the current datasheet before starting mass production.
- Operating Limits:** Please ensure the product is operated within the environmental and electrical limits specified in this datasheet. LuckyLight will not be responsible for any issues resulting from usage exceeding these specified limits.
- Special Applications:** For applications requiring high reliability or involving potential life-safety risks (such as automotive, aerospace, or medical equipment), please consult a LuckyLight representative for further assistance.
- Copyright:** The contents of this document may not be reproduced or re-transmitted without explicit permission from LuckyLight.
- Forward Bias:** LEDs must be operated with a forward bias. The driving circuit should be designed to ensure the LEDs are not subjected to reverse voltage when turned off. Continuous reverse voltage may cause metal migration and lead to device damage.
- Surface Appearance:** Surface appearance, including foreign particles or stains, is controlled within a 0.2 mm limit to meet quality standards.