

M1738-L

Infrared Receiver Module

38kHz Carrier Frequency

LuckyLight

Technical Data Sheet

Features:

- Photo detector and preamplifier in one package.
- Low voltage and low power consumption
- High photo sensitivity
- High protection ability against EMI
- Circular lens for improve the receive characteristics
- High immunity against ambient light
- Long reception range
- Pb free and RoHS compliant
- Compliance with EU REACH

Descriptions:

- The M1738-L is miniaturized receiver for remote control systems. A PIN diode and a preamplifier are assembled on lead frame and molded into a black epoxy package which operates as an IR filter. The demodulated output signal can directly be decoded by a microprocessor.

Applications:

- AV equipment such as TV, VCR, DVD, CD, MD, etc.
- CATV set top boxes
- Multi-media Equipment
- Other devices using IR remote control

Device Selection Guide

Part No.	Carrier Frequency
M1738-L	38kHz

Spec No.: M1738

Issue No.: G-Rev-4

LuckyLight Electronics Co., Ltd

Copyright © 2017 LuckyLight All Rights Reserved

Date: 09-Aug-2017

E-mail: sales@luckyLight.cn

http:// www.luckyLight.cn

Page: 1 / 8

M1738-L

Infrared Receiver Module

38kHz Carrier Frequency

Technical Data Sheet

Package Dimension:

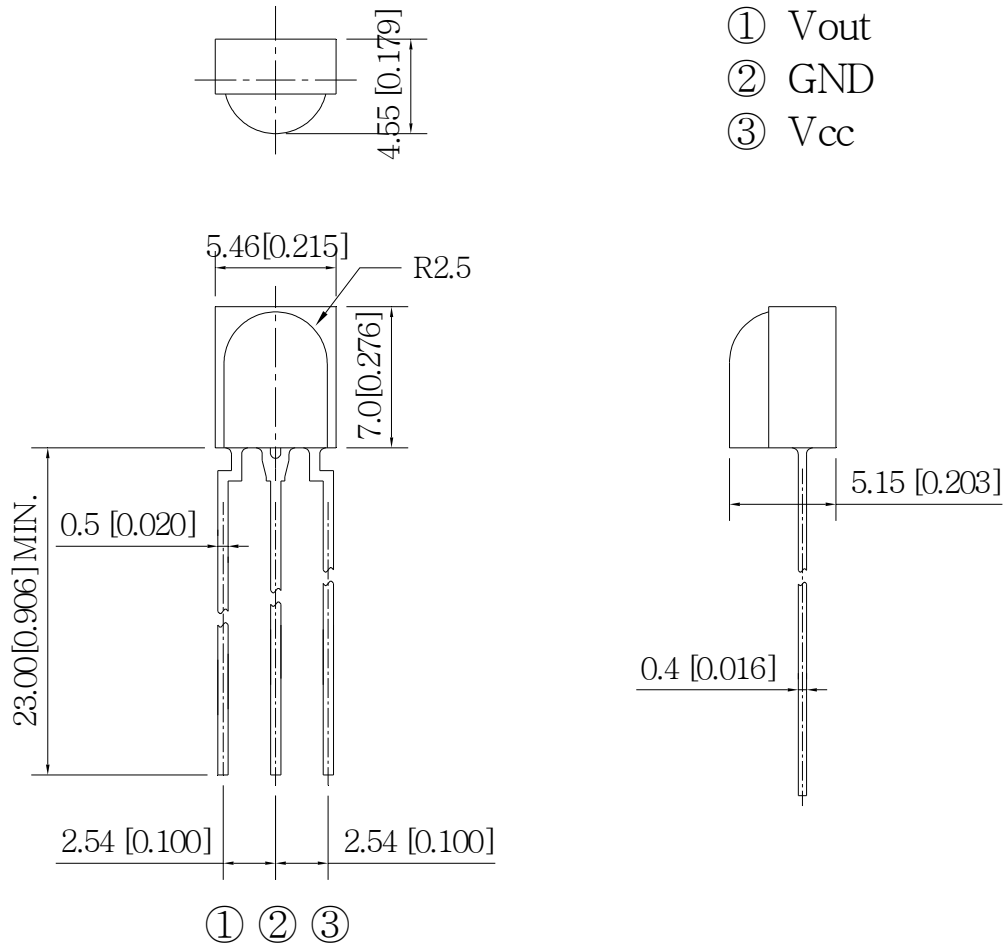

Notes:

1. All dimensions are in millimeters (inches).
2. Tolerance is ± 0.25 mm (.010") unless otherwise noted.
3. Protruded resin under flange is 1.00mm (.039") max.

M1738-L

Infrared Receiver Module

38kHz Carrier Frequency

Technical Data Sheet

Absolute Maximum Ratings at Ta=25°C

Item	Symbol	Value	Unit	Notice
Supply Voltage	V _{CC}	0~5.5	V	
Operating Temperature	T _{opr}	-25 ~ +80	°C	
Storage Temperature	T _{stg}	-40 ~ +125	°C	
Soldering Temperature	T _{sol}	260	°C	At the position of 4mm from the bottom of the package within 5 seconds.

Electrical Optical Characteristics at Ta=25°C

Parameters	Symbol	Min.	Typ.	Max.	Unit	Test Condition
Power Supply Voltage	V _{CC}	2.70	---	5.50	V	
Dissipation Current	I _{CC}	0.60	0.70	0.80	mA	V _{CC} =3.30V
Static State Current	I _{CE}	0.10	---	0.50	mA	No Signal Input
Reception Angle *	2θ _{1/2}	---	90	---	Deg	
Peak Wavelength	λ _p	---	940	---	nm	
Modulated Frequency	f ₀	---	38	---	KHz	
BMP Width	f _{BW}	2.0	---	5.0	KHz	-3Db Bandwidth
Reception Distance	L	10	12	---	m	
Low Level Output Voltage	V _{OL}	---	0.20	0.40	V	V _{IN} =0, V _{CC} =5V
High Level Output Voltage	V _{OH}	4.80	5.00	---	V	V _{CC} =5V
Low Output Pulse Width	T _{PWL}	400	---	600	μs	V _{IN} =50mVp-p
High Output Pulse Width	T _{PWH}	1500	1700	1800	μs	V _{IN} =50mVp-p

Notes:

a. All the above tests are done indoors without any sunlight: Being disturbed in 1 metre distance over the 40W fluorescent lamp or by 200Lux incandescence lamps.

Spec No.: M1738

Issue No.: G-Rev-4

LuckyLight Electronics Co., Ltd

Copyright © 2017 LuckyLight All Rights Reserved

Date: 09-Aug-2017

E-mail: sales@luckylight.cn

http:// www.luckylight.cn

Page: 3 / 8

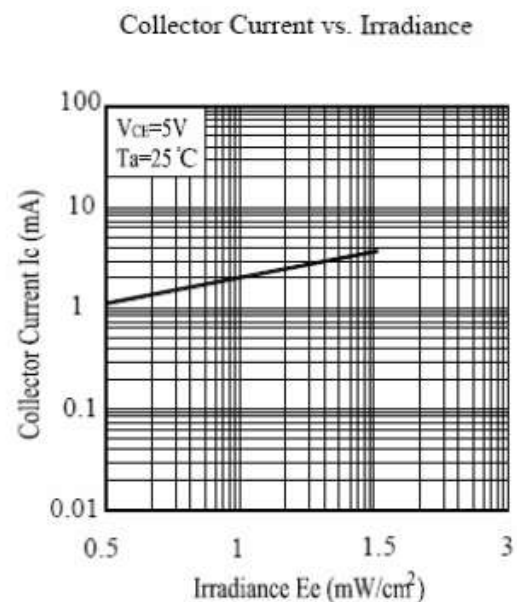
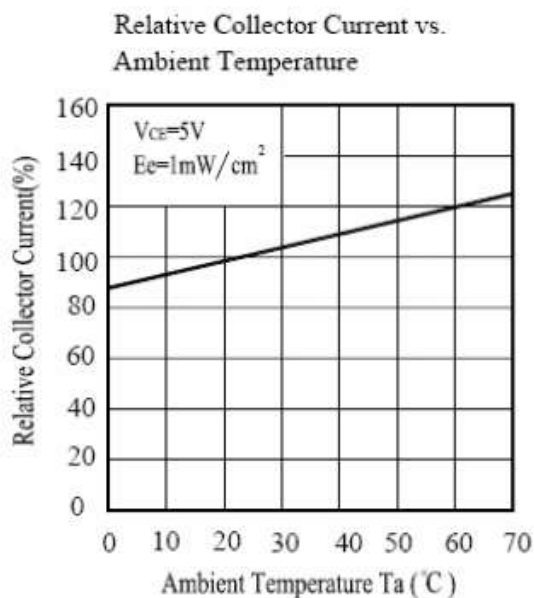
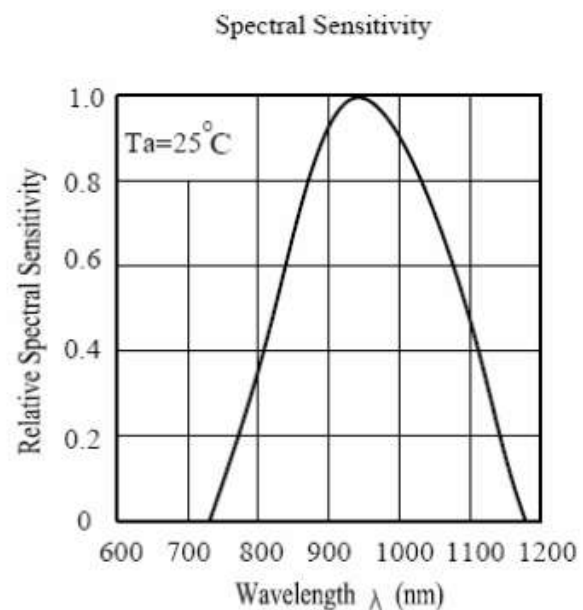
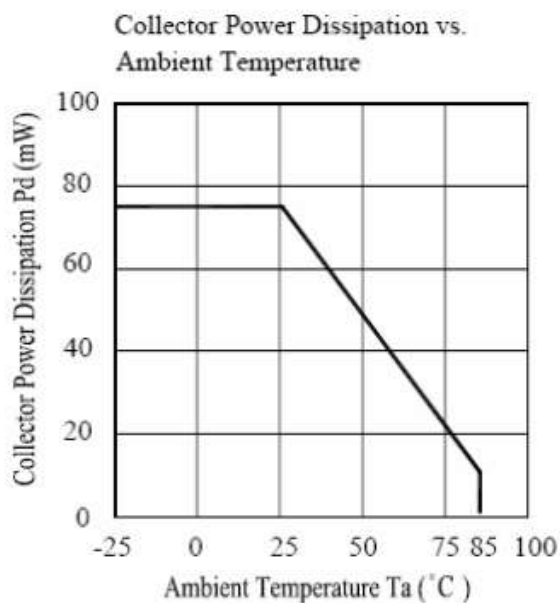
Technical Data Sheet**Typical Electrical / Optical Characteristics Curves
(25°C Ambient Temperature Unless Otherwise Noted)**

M1738-L

Infrared Receiver Module

38kHz Carrier Frequency

Technical Data Sheet

Collector Dark Current vs. Ambient Temperature

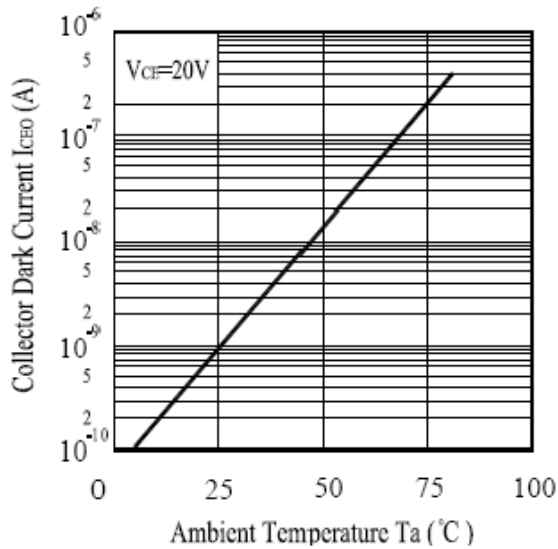

Collector Current vs. Collector-Emitter Voltage

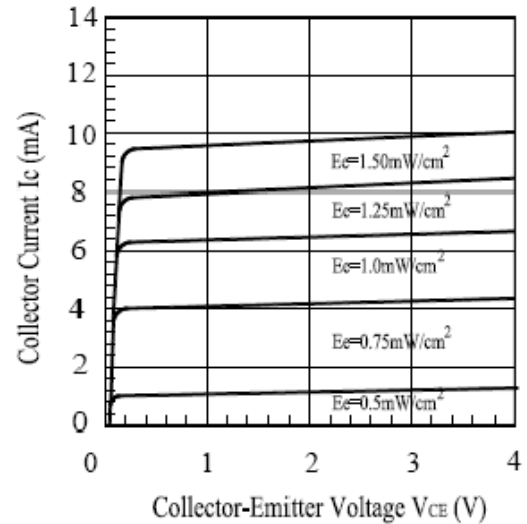

Beam Pattern

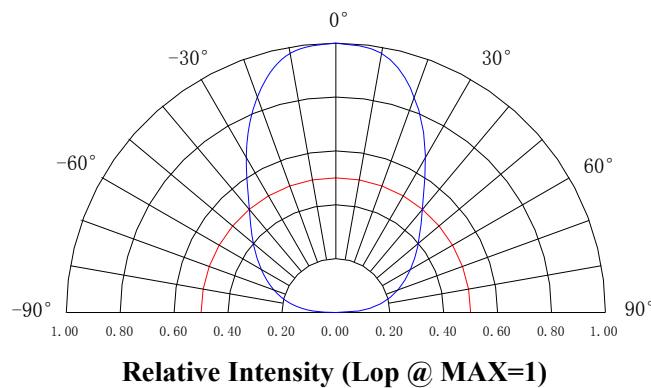

M1738-L

Infrared Receiver Module

38kHz Carrier Frequency

Technical Data Sheet

Test Wave Form:

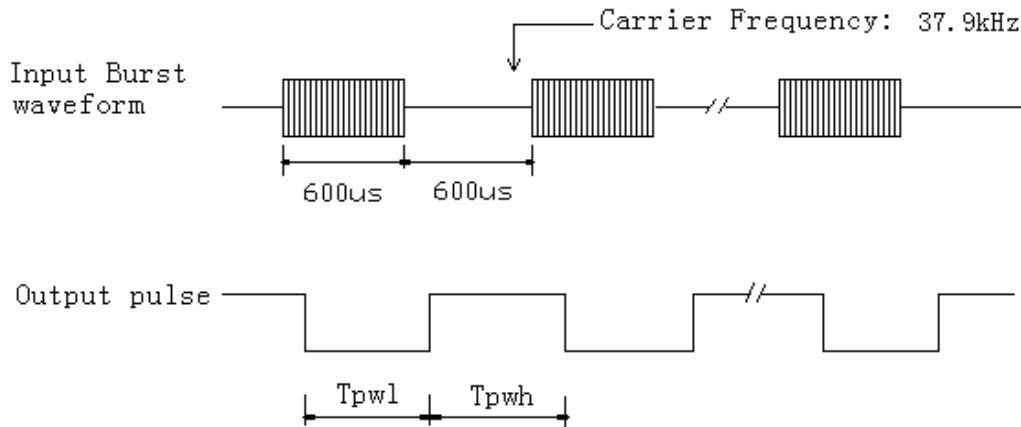

Block Diagram:

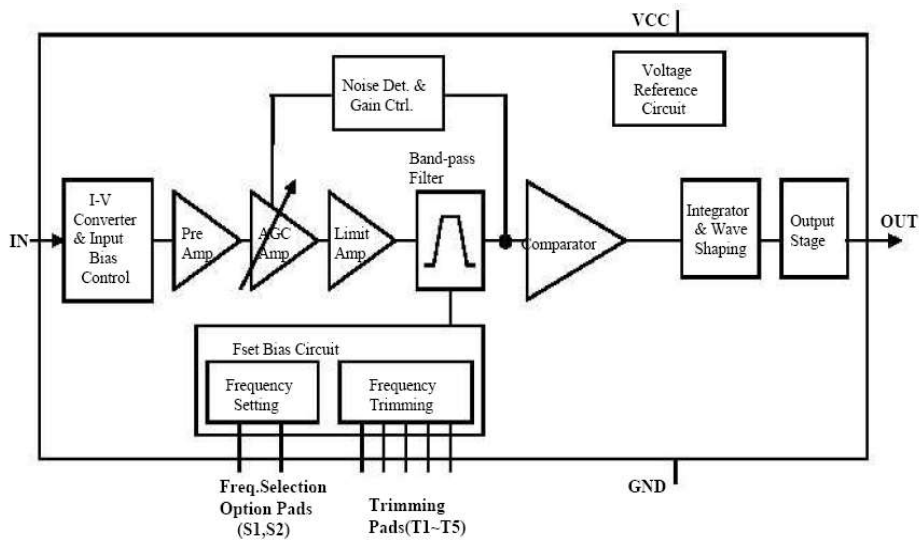

Applications Circuit:

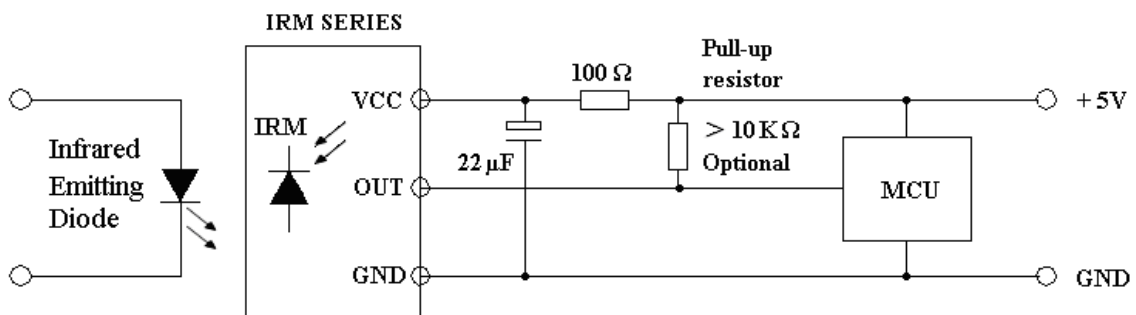

RC Filter should be connected closely between Vcc pin and GND pin.

M1738-L

Infrared Receiver Module

38kHz Carrier Frequency

Technical Data Sheet



Packing & Label Specifications:

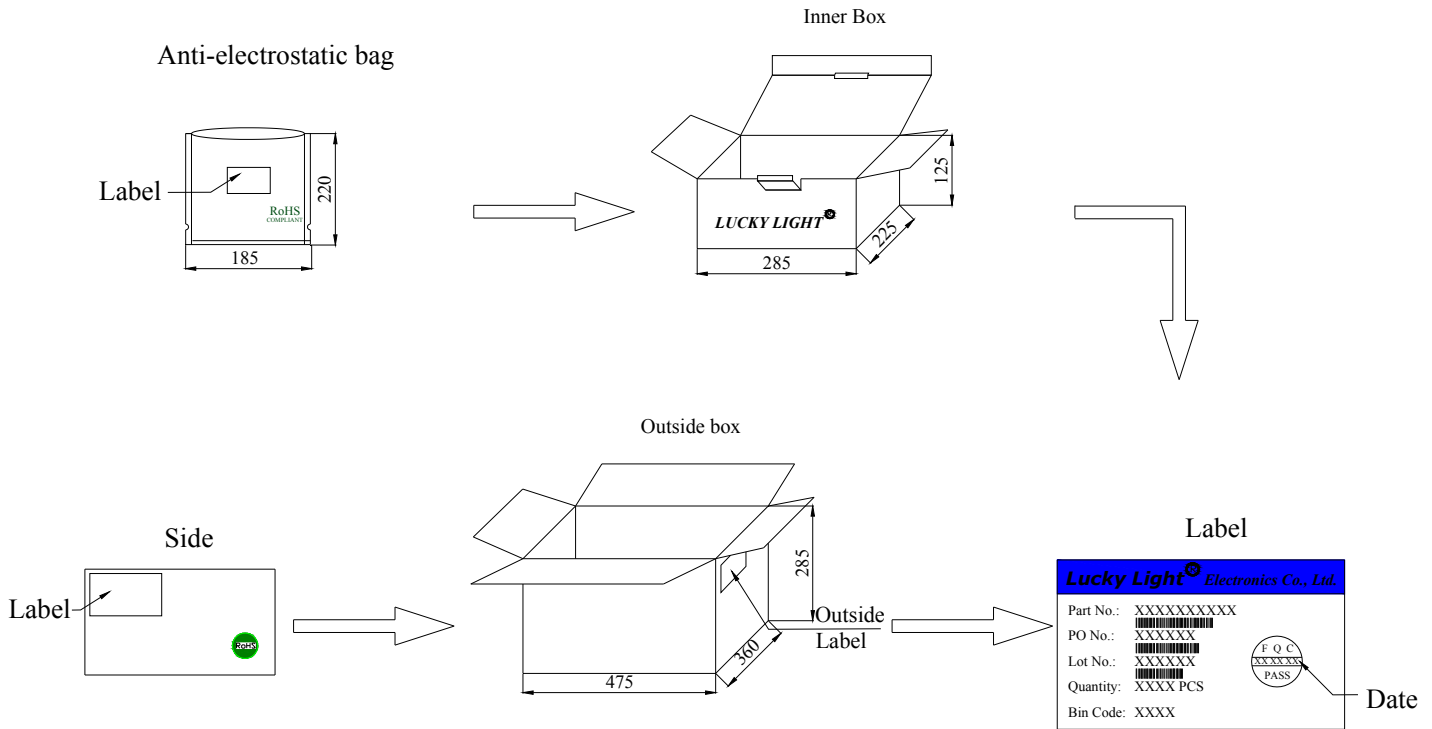

Packing Quantity:

- a. 250 PCS/bag.
- b. 5000 ~ 10000 PCS/Inner Box.
- c. 6 Inner Boxes/Outside Box.

CAUTIONS

1. General

1.1. Above specification may be changed without notice. LuckyLight will reserve authority on material change for above specification. When using this product, please observe the absolute maximum ratings and the instructions for use outlined in these specification sheets. LuckyLight assumes no responsibility for any damage

Technical Data Sheet

resulting from use of the product which does not comply with the absolute maximum ratings and the instructions included in these specification sheets

- 1.2. DIP Type IR receiver modules can be mounted in any position. The leads may be bent, but the bend should not be less than 2mm from the bottom of the plastic package. During bending, force should not be transmitted from the leads to the package (e.g. by spreading the leads). If the device is mounted near heat generating components, the resulting increase in ambient temperature should not exceed the specified ratings.

2. Storage

- 2.1. The IR receiver modules should be used within a year
- 2.2. The devices are sensitive to damage due to moisture release if they are subjected to infrared reflow or a similar soldering process (e.g. wave soldering) without being properly dried. Be sure to observe the following storage conditions:
- 2.2.1. Storage temperature 10 °C to 30 °C
- 2.2.2. Storage humidity at 60 % RH maximum
- 2.3. The IR receiver modules used within 72hours after opening the package

3. Soldering

Protection against overheating is essential when a device is being soldered. It is recommended, where the design permits, that the length of the leads between the solder joint and the package be left as long as possible. The maximum permissible soldering temperature for plastic encapsulated devices is governed by the maximum permissible heat that may be applied to the plastic rather than by the maximum permissible junction temperature of the die.

Recommended soldering conditions:

Soldering Iron		Wave Soldering	
Temperature	300°C Max.	Pre-heat	100°C Max.
Soldering Time	3 sec. Max. (one time only)	Pre-heat Time	60 sec. Max.
		Temperature	260°C Max.
		Soldering Time	5 sec. Max.